



MIS TOOLS

BUILDING METAL PRODUCTS TRADING LLC



COMPANY PROFILE

ENGINEERING YOUR CONNECTIONS

www.mis-eqpt.com
Sales@mis-eqpt.com
globalsales@mis-eqpt.com

INTRODUCTION

DISCOVER MIS TOOLS

At **MIS Tools, Building Metal Products Trading LLC,**

our founding mission is centered on delivering precise products to the industry exactly when needed.

Our specialized team of engineers champions a motto that prioritizes endowing customers with unparalleled technical prowess in riveting and fastening solutions.

Operating round the clock, 24 hours a day, 365 days a year, our unwavering dedication ensures we stand ready to cater to our customers' every riveting need.

Furthermore, we pride ourselves on offering tailored, customized solutions meticulously crafted to meet your project's unique demands, all while maintaining a competitive edge in costs.

WHO WE ARE

We are a team of passionate Engineers with over 15+ years of experience in the field of Fasteners and Tools.

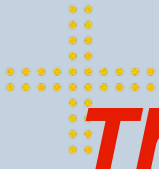

The Riveting Revolution



STANDARD BLIND RIVETS

Also known as open end blind rivets, pop rivets, tucker rivets etc are widely used in various applications like furniture metal, fabrication, switchgear, cars, seating, enclosures, HVAC, Ducting, Shelters, Housing etc.

Material: Aluminium, Steel, Stainless Steel, Monel, Copper

CLOSED BLIND RIVETS

Closed-end blind rivets are typically utilized in applications that demand weather resistance. They are completely sealed from air and water elements, thereby providing a waterproof joint. Some common uses include sandwich panels for warehouses and cold rooms, as well as in metal roofing and refrigerated trucks.

Material: Aluminum, Steel, Stainless steel.

HIGH STRENGTH RIVETS

High-strength rivets find extensive use in applications necessitating superior resistance to breaking loads. Variants like Monolocks, Nowlocks, Hemfirm, etc., offer enhanced strength compared to standard blind rivets, boasting excellent clamping force and visual appeal on the set side. .



Materials : Aluminum, Steel and stainless steel

Lockbolts

A LockBolt comprises a hardened metal pin and collar that create a precise clamp force, securing assembled parts. Commonly used in heat exchangers, HVAC, scaffolding, and formwork, as well as unit loading devices. Sizes range from 4.8 to 12mm, with a heavy-duty 16mm option available. Materials include aluminum, steel, and stainless steel.



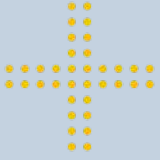

Multi-grip Blind Rivets



Multigrip Blind Rivets: Multigrip and polygrip blind rivets represent the most versatile versions among standard blind rivets. These are the most versatile among standard options, offering a wider grip range for enhanced clamping and a sleek bulb-like appearance.

Materials: Aluminum, steel, and stainless steel

Monobolt/ Interlok Rivets



Monobolt rivets are single-piece, high-strength blind rivets with a break-off mandrel. Ideal for structural applications in construction, automotive, and aerospace, they offer robust, vibration-resistant connections and reliable sealed joints.

Materials: Aluminum, steel, stainless steel

Bulbtite Rivets



Bulbtite rivets are the gold standard in roofing applications. The benefits include application in thin and soft materials without risk of cosmetic and structural damage. Bulbtite rivets are weather resistant and are widely used in standing seam systems.

Sizes: 5.2 mm, 6 mm and 7.7 mm with varied grip lengths

Pop Nuts, Rivet Nuts



We offer a full range of rivet nut and rivet nut tools
Types: Pneumatic (Air Operated Hydraulic Actuated)
Battery riveting and rivet nut tools
Hand rivet and rivet nut tool
Solutions for high throughput applications

Self-pierce rivets/ Self clinch Fasteners

Self-pierce rivets (SPRs) bypass pre-drilled holes, swiftly joining sheets by piercing the top and extruding on the bottom for strong, reliable joints. They work across materials and are faster to install.

Self-clinching fasteners create lasting joints without extra steps, perfect for thin sheets and tight spaces. Both are quick, strong options for sheet metal assembly, chosen based on needs like material compatibility and permanence. Industries like automotive, electronics, and aerospace rely on their efficiency.



SELF CLINCH STUDS



SELF CLINCH NUTS



BLIND STANDOFFS



PANEL FASTNERS



SELF CLINCH TOOLS



SELF PIERCE CASSETTE

www.reallygreatsite.com

BOLTS & NUTS

Nuts and bolts form a robust fastening team, fortifying thinner materials like sheet metals, aluminum, plastics, and carbon fiber. They create secure threaded points for attaching bolts and accessories, perfect for setups requiring occasional disassembly. Found in switchgear, enclosures, furniture, generator canopies, and aluminum substructures, they come in sizes from M3 to M12, catering to various project needs. We offer a comprehensive array of Nuts & Bolts to meet your every need.



HEX BOLT



HDG BOLT



ALLEN BOLT

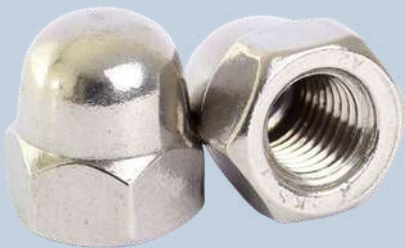

DOME NUTS



SQUARE NUTS



HEX NUTS



WASHERS & THREADED BARS

Washers work silently yet effectively, reinforcing connections in thinner materials across diverse applications. From sheet metals to aluminum and carbon fiber, they ensure stability for bolts and accessories, crucial for occasional disassembly needs. These vital components are omnipresent in switchgear, enclosures, furniture, generator canopies, and aluminum substructures. Sizes spanning from M3 to M12 cater to various project demands. Discover a comprehensive range of washers at our supply hub, ensuring we have all types to fortify your assemblies.



FLAT WASHERS



SPRING WASHERS



FENDER WASHER



THREADED BARS



COUPLER NUT



EYE BOLT



SCREWS

SELF TAPPING/GYPSUM/MACHINE SCREWS/SPECIAL PURPOSE

Screws, the backbone of fastening, secure materials with precision across various applications. From sheet metals to aluminum and carbon fiber, they create steadfast connections for diverse assemblies, ensuring stability and reliability. These indispensable components play a pivotal role in switchgear, enclosures, furniture, generator canopies, and aluminum substructures. Available in sizes ranging from M3 to M12, screws accommodate different project requirements. Explore our extensive collection at the supply hub, offering a variety of screws to match your assembly needs with precision and strength.



WINDOW SCREW



MACHINE SCREW



SELF TAPPING SCREW



WOOD CONSTRUCTION SCREW



GYPSUM SCREW



SOCKET HEAD SCREW



SELF DRILLING SCREWS

Screws / Threaded Rods / Bolts / Nuts / Washers / Anchors / Brass / Stainless Steel

Self-drilling screws are the linchpin of fastening technologies, intricately engineered to securely affix materials across multifarious applications. From the precision of Stitch screws to the versatility of pan heads, the flush fit of counter sunk head screws, and the durability of ruspertcoathead screws, each variant serves a distinct purpose in ensuring steadfast connections.

Explore our comprehensive array at the supply hub, where an extensive selection of self-drilling screws awaits to match your assembly needs with technical excellence and reliability.



STITCH SCREW



SD SCREWS WITH METAL CAPS



COUNTER SUNK SCREW



RUSPERT COATED SCREWS



SCREWS FOR SKYLIGHTS



BIMETAL SCREWS

SHEAR STUDS/BUTYL TAPES/CAPS

Butyl Tapes/screw caps/accessories

Self-drilling screws are the linchpin of fastening technologies, intricately engineered to securely affix materials across multifarious applications. From the precision of Stitch screws to the versatility of pan heads, the flush fit of counter sunk head screws, and the durability of ruspertcoathead screws, each variant serves a distinct purpose in ensuring steadfast connections.

Explore our comprehensive array at the supply hub, where an extensive selection of self-drilling screws awaits to match your assembly needs with technical excellence and reliability.

TitanBond®



BUTYL TAPES



SHEAR STUDS



**COLOUR
SCREW CAPS**



FOAM FILLER BLOCKS

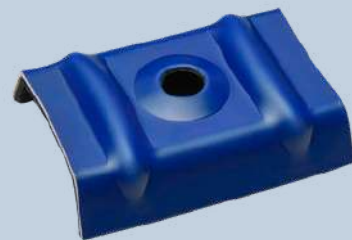

SADDLE WASHERS

Rivdom EBZ 1



This tool is a lightweight powerhouse, weighing only 1.6 kg with a compact build. It handles blind rivets up to 5.0 mm effortlessly, boasting a setting force of 10,000 N thanks to its new brushless motor. Lightning-fast, it sets rivets in under a second, processing 30 in just 60 seconds—twice the speed of comparable tools. Its automatic mandrel removal ensures quick, seamless operation without any need to tilt the tool.

Rivdom EBZ Zero



A LockBolt comprises a hardened metal pin and collar that create a precise clamp force, securing assembled parts. Commonly used in heat exchangers, HVAC, scaffolding, and formwork, as well as unit loading devices. Sizes range from 4.8 to 12mm, with a heavy-duty 16mm option available. Materials include aluminum, steel, and stainless steel.

Rivdom E-BZ Zero S



Rivdom's RivSmart: compact, expertly handling blind rivets up to 4.0 mm in production lines. Maintenance is tool-free—swap clamping jaws and nosepieces instantly.

Choose your return mode: manual needs continuous trigger pressure until rivet shearing, while automatic mode activates with a light trigger press. After shearing, RivSmart swiftly resets, ensuring a rapid riveting cycle.

Bluebird Series Rivet Tools:



Bluebird Raptor



Completely redesigned compact rivet nut tool
Lightweight at 1.9 Kgs only
Highly reliable motor with reduced component wear
Fast operation and quick setting of rivet nuts .Convenient reverse switch. New Hydraulic oil circuit design improves reliability
High quality plastic and aluminium components
Setting capacity m3 to m12 in all materials
Nosekits included.
High setting force upto 35KN.Easy repair and maintenance.
1 year warranty backed by excellent service support

Bluebird Falcon



High torque Brushless motor designed for strong rivets.
Improved ergonomic design.
Industrial quality design with CNC alloy gears.
Quick dismantle Nose assembly for faster maintenance.
High quality non contact induction switch ensures longer life span.
Retaining Nose tips for automatic mandrel evacuation.
Fast charging High capacity battery confirms to CE standards.
Led lights indicate status and illuminate application area.
Led indicator on battery indicates charge status.
Capacity :2.4 mm to 6.4 mm rivets. High pull force of upto 20 Kn.

Bluebird Eagle 2



Light weight at only 1.35 Kgs.
Ergonomic design reduces operator fatigue
Sturdy trigger ensures fast and efficient operation.
Redesigned Hydraulic system
Low Air consumption reduced operational costs
Vaccum absorption system ensures quick turnaround
Transparent mandrel collector
Safety feature disconnects Vaccum system upon removal of mandrel collector.
Easy oil change and maintenance
Pivoted Air connector with cutoff switch. Setting capacity: 3.2mm to 5 mm

DUSS



MADE IN GERMANY SINCE 1920

DRILLS (ROTARY AND HAMMERS)
DIAMOND CORE DRILLS(WET AND DRY)
BREAKERS
DEMOLITION HAMMERS
ACCESSORIES



PROJECTS SUPPLIED

Outdoor theater king Salman park, KSA
PCEE majma, KSA
Landmark warehouse extension
TSE Angola & TSE Nigeria
SEPCO, KSA
VERT, Kenya
Public and Private Property Schools Project,Doha,qatar
Hyundai HMME factory Project
Aramco World Cup Stadium,DAMMAM,KSA
Mabani Aircraft Hangar project
Zabeel Tower,Dubai
Difc Project
Misk project Saudi Arabia
Etihad project hanger 7, H6D, Abu Dhabi

SCOPE OF SUPPLY

- Bulbtite rivets Roofing rivets
- Closed end rivets Bi Metal Self
- Drilling Screws and colour caps
- Carbon Steel Self Drilling Screws
- Shear Studs
- Nut Bolts ,Washers

ENGINEERING YOUR CONNECTIONS

TECHNICAL DATA SHEETS AND TEST REPORTS

RIVETS

TECHNICAL DATASHEET

4.8 X11.5 ALU/SS CLOSED END RIVET

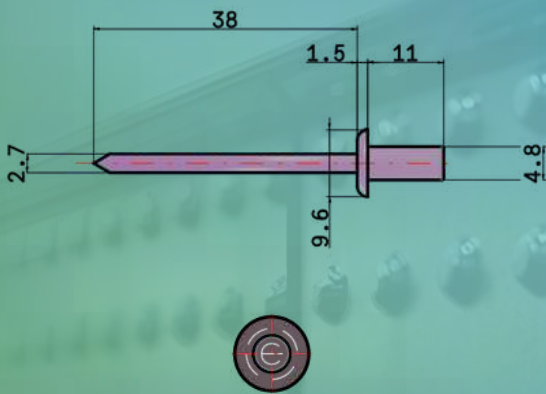

MATERIAL SPECIFICATIONS

**BODY : ALUMINIUM 5050 SERIES
MANDREL: POLISHED SS304**

ITEM NUMBER/CODE :

**NW48115ASSS
SCT48115ASSS
TEN48115ASSS**



MECHANICAL VALUES (N)

MIN. SHEAR STRENGTH



MIN. TENSILE STRENGTH

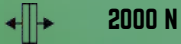

BORE HOLE DIAMETER (MM)



4.9 MM

DIMENSIONS (MM)

**SHAFT DIAMETER (D) :4.8 MM
SHAFT LENGTH (L): 11.05-11.7
HEAD HEIGHT (K) :2.0 (MAX)
HEAD DIAMETER (DK) :8.3-10.1 MM
MANDREL DIAMETER (DM): 2.7 MM(MAX)**

STANDARD

**DIN 7337
GB/T 16475-2023
GB/T 3190-2020
ROHS/2.0/2011/65/EU**

CLAMPING RANGE (MM)



5.0 UP TO 6.5

ADDITIONAL INFORMATION

**PACKING :500 PCS /BOX
HSCODE :73182300/76161000**



江阴市春瑞金属制品有限公司

jiangyin ChunRui Metal Products Co.,Ltd.

地址: 江苏省江阴市金石路 256 号

ADD: NO.256 Jinshi Road ,Jingyin City, Jiangsu Province

电话 TEL: 0510-86130790 传真 FAX: 0510-86130780

质量保证书

(CERTIFICATED QUALITY LEVEL)

日期 (DATE): 2025.05.05

合同号 S/C NO.	--	客户名称 CUSTOMER	上海承泰金属五金 制造有限公司	订单号 ORDER.NO.	A325042104 A325042501
证书编号 CERT.NO.	--	钢种 GRADE	304B/304H	表面质量 SURFACE	OK

化学成分% (CHEMICAL COMPOSITION)

炉号 Heat No.	规格 (mm) Size	C	Cr	Mn	Ni	P	S	Si	Cu	Mo	N
S250320AA07	4.35	0.020	18.09	1.04	8.01	0.029	0.001	0.25	0.72		
NY250406AW12	2.63	0.072	18.13	1.23	8.02	0.040	0.001	0.38			

检查结果 (INSPECTION RESULTS)

检查项目 Spec 包装编号 Package No.	规格 (SIZE) (mm)	抗拉 (Mpa)	延伸率 (EL)(%)	炉号 Heat No.	净重 IB. W. (KG)	备注 Remarks
	+0-0.02					
	4.35	6115/6227		S250320AA07	2036.8	21 件
	2.63	6177/6233		NY250406AW12	2024.8	20 件
备注 REMARK	1.表面质量、尺寸均符合合同约定或相关标准要求。 The surface quality,dimension are in line with the requirements of the contract or the relevant standards. 2.以上为抽样测试数据, 订单技术指标波动值, 按合同约定或参考相关国内(国际)标准。 Above is the sample test data,technical index fluctuations in the contract value of the order,according to the contract or the relevant domestic (international) standards.					



Rivet Body : 4.8 x 11.5 alu/ss closed end

产品检测报告单 CERTIFICATE OF TEST

客户名称 (CUSTOMER) : 承泰五金科技江苏股份有限公司

ZWLY/JL-2001/A

产品名称 Description	规格 Size (mm)	状态 Temper	数量 Quantity (Kg)	执行标准 Specification	炉批号 LotNumber
5056	φ7.9	H32	608.2	GB / T 16475 - 2008 GB / T 3190 - 2020 RoHS2.0 /2011/65/EU	56250218-1
	φ9.0		425.6		56250218-1

化学成分 (Chemical Composition) (%)

元素 Element	Mg	Mn	Cr	Fe	Zn	Cu	Ti	Si	Hg	CrVI	Pb	Cd	PBB	PBDE
标准要求 Test Item	4.5-5.6	0.05-0.20	0.05-0.20	≤0.40	≤0.10	≤0.10	≤0.10	≤0.30	1000mg/kg	1000mg/kg	1000mg/kg	100mg/kg	N/A	N/A
检测结果 Test Result	4.650	0.063	0.062	0.153	0.007	0.008	0.036	0.058	ND	Negative	ND	ND	N/A	N/A

力学性能 (Mechanical Properties)

检测项目 Test Item	抗拉强度 σ_b Tensile Strength (Mpa)	延伸率 δ_{10} Elongation (%)	硬度 (HV) 5kgf/30S Hardness
检测结果 Test Result	329	11	107 101

其它要求 (Size Variations, Appearance)

检测项目 Test Item	尺寸公差 Size Variations (mm)	晶粒级别 Grain level	组织状态 Organization state	表面质量 Appearance
检测结果 Test Result	OK ±0.005	>4	变形晶粒	OK 合格章

检验 (inspectors) 李启霞

主管 (Manager) 汪海宽

合格专用章 (Badge)

签发日期 (Date of issuance) : 2025年3月10日



Test and Inspection report

Closed End Alu/ss				DATE: 2025.8.26						
		DRAWING								
DESC.										
4.8*11.5										
ALU/SS304										
APPEARANCE		OK								
SIZE		4.8*11.5								
DIA	①	D1	4.8	4.65 4.88	① 4.72	② 4.72	③ 4.70	④ 4.70	⑤ 4.70	RESULT PASS
	②	D2	9.6	8.30 10.10	9.68	9.52	9.62	9.56	9.36	PASS
	③	k	2.0 max		1.76	1.78	1.76	1.78	1.78	PASS
	④	d	2.77 max		2.62	2.60	2.60	2.60	2.60	PASS
	⑤	L	11.50	11.50 12.50	12.20	11.94	12.24	12.26	12.18	PASS
	⑥	P	27.0 max		① 34.56	② 34.62	③ 34.40	④ 33.96	⑤ 34.34	PASS
					① 3526	② 3394	③ 3467	④ 3385	⑤ 3410	RESULT
				2456	2578	2488	2495	2516		
TENSILE(N)		3100							PASS	
SHEAR(N)		min							PASS	
		2200								
		min								
检 查 结 果：	OK									
人员：	陶元良									



TECHNICAL DATASHEET

5.2 X (L) ALU/ALU BULBTITE RIVET

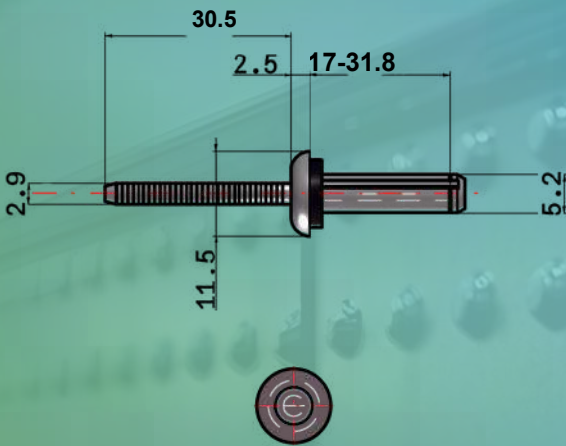

MATERIAL SPECIFICATIONS

BODY : ALUMINIUM 5056 SERIES
MANDREL : 7A03
FINISH : POLISHED
WASHER : NEOPRENE

ITEM NUMBER/CODE :

NWS217BT / NWS219BT / NWS222BT NWS225BT / NWS228BT / NWS232BT



MECHANICAL VALUES (N)

MIN. SHEAR STRENGTH

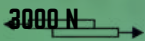

MIN. TENSILE STRENGTH



BORE HOLE DIAMETER (MM)



5.3 MM

DIMENSIONS (MM)

SHAFT DIAMETER (D) : 5.2 MM
SHAFT LENGTH (L) : 17 TO 31.8 MM
HEAD HEIGHT (K) : 3.2 (+/- 0.03) MM
HEAD DIAMETER : 11.3(+/-0.03) MM
MANDREL DIAMETER : 2.9(+/-0.01) MM

STANDARD

DIN 7337
GB/T 16475-2023
GB/T 3190-2020
ROHS/2.0/2011/65/EU

CLAMPING RANGE (MM)



1.3 - 19.1 MM (FOR VARIED RIVET LENGTHS)

ADDITIONAL INFORMATION

PACKING : 500 PCS /BOX , 250 PCS/BOX
HSCODE : 73182300/76161000



Ningbo Zhaosheng Aluminium Industry Co., LTD

INSPECTION CERTIFICATE

No.23-1 Renmin North Road, Longshan Town, Cixi City, Ningbo, Zhejiang Province, China
TEL: (0574)63708208 18357402823

客户名称 (CUSTOMER) :

Rivet Body : 5.2 x 19.1 Alu/AluBulbrite

产品牌号 Code	规格 Size (mm)	状态 Temper	数量 Quantity (Kg)	执行标准 Specification	批号
5056	Ø4.9 _{±0.02}	H32	993.1	GB/T 16475 - 2008 GB/T 3190 - 2020 RoHS2.0 /2011/65/EU	/
					/

化学成分 (Chemical Composition) (%)

炉号 Heat Number	元素 Element 标准要求 Test Criteria	Si	Fe	Cu	Mg	Mn	Cr	Zn	Ti
25060102-08	测试数据 Test Data	≤0.3 0.060	≤0.4 0.133	≤0.1 0.030	4.5 - 5.6 4.740	0.05 - 0.2 0.080	0.05 - 0.2 0.076	≤0.1 0.005	— /

力学性能 (Mechanical Properties)

检测项目 Test Item	抗拉强度σ _b Tensile Strength (MPa) ≥310	硬度 HV _{0.05} Hardness ≥84
检测结果 Test Result	OK	101

其它要求 (Size Variations, Appearance)

检测项目 Test Item	尺寸公差 Size Variations (mm)	表面质量 Appearance
检测结果 Test Result	OK	OK

检验 (Inspector) : 周晨涛

签发日期 (Date of issuance) : 2025年06月15日



TECHNICAL DATA SHEETS AND TEST REPORTS

SCREWS

TECHNICAL DATASHEET

CARBON STEEL SELF DRILLING SCREW 5.5/6.3 X L*

- FASTENER MATERIAL: CARBON STEEL WASHER MATERIAL: CARBON STEEL WITH EPDM BONDED
- WASHER
- DRILL POINT: HARDENED CARBON-STEEL NO.3 POINT (DRILL CAPACITY 2.0 TO 5.0 MM) :
- DIAMETER : 5.5/6.3 HI LO THREAD
COATING : ZINC,RUSPERT 500,1000,1500,2000(SILVER,GREY WHITE)

TENSILE STRENGTH

GAUGE	#6	#8	#10	#12	#14
MM	3.5	4.2	4.8	5.5	6.3
KN	5.0	7.0	10.0	12.5	17.0

SHEAR STRENGTH

GAUGE	#6	#8	#10	#12	#14
MM	3.5	4.2	4.8	5.5	6.3
KN	2.9	4.4	6.3	8.4	12.27

PULL OUT STRENGTH

GAUGE	DRILL POINT-#2, #3				#5	
MM	1.6	2.0	3.0	3.2	5.0	6.0
KN	3.8	4.9	7.9	9.3	11.21	12.5

TORSIONAL STRENGTH

GAUGE	#6	#8	#10	#12	#14
MM	3.5	4.2	4.8	5.5	6.3
NM	2.8	4.5	6.5	10.0	14.0

PERFORMANCE & MECHANICAL DATA

	STEEL THICKNESS	4.8 MM(#10)	5.5 MM(#12)	6.3 MM(#14)
SHEAR STRENGTH(N)		6700	10400	13400
TENSILE STRENGTH(N)		9500	13900	15500
TORSIONAL STRENGTH(N-M)		6.5	10.0	14.0
PULL OUT STRENGTH(N)	2.3MM	4690	4700	5000
	3.2MM	7480	7610	7930
	4.5MM	9680	12700	13500
	6.0MM		13900	15000
DRILLING CAPACITY	MAX.MM	3.5	4.5	6.0

MENTIONED VALUES ARE ULTIMATE PEAK LOADS AND DO NOT CONTAIN SAFETY FACTORS.

STRENGTHS ARE INDICATIVE AND MAY VARY ON APPLICATION, SUBSTRATE AND OTHER CONDITIONS

*LENGTHS AVAILABLE FROM 20 MM TPTD 250+MM

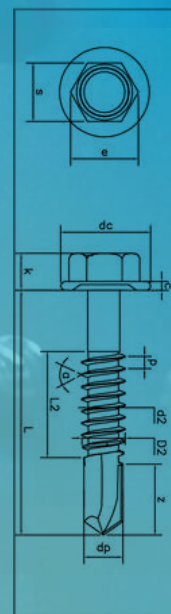

TECHNICAL DATASHEET

BI METAL SELF DRILLING SCREW 5.5x L



- FASTENER MATERIAL: BI METAL STAINLESS STEEL A2 (AISI 304)
- WASHER MATERIAL: STAINLESS STEEL A2 (AISI 304) WITH EPDM BONDING.
- DRILL POINT: HARDENED CARBON-STEEL NO.3 POINT (DRILL CAPACITY 2.0 TO 5.0 MM)
- DIAMETER: 5.5 FULL THREAD
- COATING : ZINC,RUSPERT 500,1000,1500,2000(SILVER,GREY WHITE)

TENSILE STRENGTH

GAUGE	#6	#8	#10	#12	#14
MM	3.5	4.2	4.8	5.5	6.3
KN	5.0	7.0	10.0	12.5	17.0

SHEAR STRENGTH

GAUGE	#6	#8	#10	#12	#14
MM	3.5	4.2	4.8	5.5	6.3
KN	2.9	4.4	6.3	8.4	12.27

PULL OUT STRENGTH

GAUGE	DRILL POINT-#2, #3					#5
MM	1.6	2.0	3.0	3.2	5.0	6.0
KN	3.8	4.9	7.9	9.3	11.21	12.5

TORSIONAL STRENGTH

GAUGE	#6	#8	#10	#12	#14
MM	3.5	4.2	4.8	5.5	6.3
NM	2.8	4.5	6.5	10.0	14.0

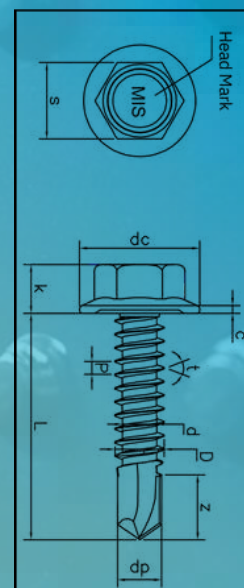

STRENGTHS ARE INDICATIVE AND MAY VARY ON APPLICATION, SUBSTRATE AND OTHER CONDITIONS
*LENGTHS AVAILABLE FROM 20 MM TPTO 250+MM

PERFORMANCE & MECHANICAL DATA

	STEEL THICKNESS	4.8 MM (#10)	5.5 MM (#12)	6.3 MM (#14)
SHEAR STRENGTH(N)		6700	10400	13400
TENSILE STRENGTH(N)		9500	13900	15500
TORSIONAL STRENGTH(N-M)		6.5	10.0	14.0
PULL OUT STRENGTH(N)	2.3MM	4690	4700	5000
	3.2MM	7480	7610	7930
	4.5MM	9680	12700	13500
	6.0MM		13900	15000
DRILLING CAPACITY	MAX.MM	3.5	4.5	6.0



TECHNICAL DATASHEET

BIMETAL SELF DRILLING SCREW 5.5/6.3 X L*

- FASTENER MATERIAL: BI METAL STAINLESS STEEL A2 (AISI 304)
- WASHER MATERIAL: STAINLESS STEEL WITH A2 (AISI 304) WITH EPDM BONDED
- DRILL POINT : HARDENED CARBON-STEEL NO.3 POINT (DRILL CAPACITY 2.0 TO 5.0 MM)
- DIAMETER: 5.5/6.3 HIGH THREAD
- COATING : ZINC,RUSPERT 500,1000,1500,2000(SILVER,GREY WHITE)

TENSILE STRENGTH

GAUGE	#6	#8	#10	#12	#14
MM	3.5	4.2	4.8	5.5	6.3
KN	5.0	7.0	10.0	12.5	17.0

SHEAR STRENGTH

GAUGE	#6	#8	#10	#12	#14
MM	3.5	4.2	4.8	5.5	6.3
KN	2.9	4.4	6.3	8.4	12.27

PULL OUT STRENGTH

GAUGE	DRILL POINT-#2, #3					#5
MM	1.6	2.0	3.0	3.2	5.0	6.0
KN	3.8	4.9	7.9	9.3	11.21	12.5

TORSIONAL STRENGTH

GAUGE	#6	#8	#10	#12	#14
MM	3.5	4.2	4.8	5.5	6.3
NM	2.8	4.5	6.5	10.0	14.0

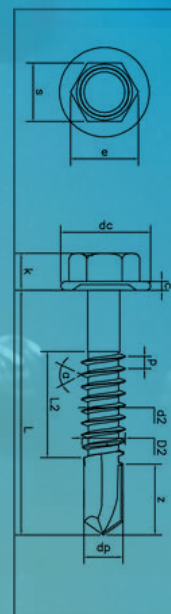

STRENGTHS ARE INDICATIVE AND MAY VARY ON APPLICATION, SUBSTRATE AND OTHER CONDITIONS
*LENGTHS AVAILABLE FROM 20 MM TPTO 250+MM

PERFORMANCE & MECHANICAL DATA

	STEEL THICKNESS	4.8 MM (#10)	5.5 MM (#12)	6.3 MM (#14)
SHEAR STRENGTH(N)		6700	10400	13400
TENSILE STRENGTH(N)		9500	13900	15500
TORSIONAL STRENGTH(N-M)		6.5	10.0	14.0
PULL OUT STRENGTH(N)	2.3MM	4690	4700	5000
	3.2MM	7480	7610	7930
	4.5MM	9680	12700	13500
	6.0MM		13900	15000
DRILLING CAPACITY	MAX.MM	3.5	4.5	6.0

TECHNICAL DATASHEET

CARBON STEEL SELFDRILLING SCREW 5.5x L

FASTENER MATERIAL: GI CARBON STEEL WASHER MATERIAL: GI CARBON STEEL WITH EPDM
 BONDED DRILL POINT: HARDENED CARBON-STEEL NO.3 POINT (DRILL CAPACITY 2.0 TO 5.0 MM)
 DIAMETER: 5.5 FULL THREAD

TENSILE STRENGTH

GAUGE	#6	#8	#10	#12	#14
MM	3.5	4.2	4.8	5.5	6.3
KN	5.0	7.0	10.0	12.5	17.0

SHEAR STRENGTH

GAUGE	#6	#8	#10	#12	#14
MM	3.5	4.2	4.8	5.5	6.3
KN	2.9	4.4	6.3	8.4	12.27

PULL OUT STRENGTH

GAUGE	DRILL POINT-#2, #3					
	#2	#3	#4	#5	#6	#7
MM	1.6	2.0	3.0	3.2	5.0	6.0
KN	3.8	4.9	7.9	9.3	11.21	12.5

TORSIONAL STRENGTH

GAUGE	#6	#8	#10	#12	#14
MM	3.5	4.2	4.8	5.5	6.3
NM	2.8	4.5	6.5	10.0	14.0

STRENGTHS ARE INDICATIVE AND MAY VARY ON APPLICATION, SUBSTRATE AND OTHER CONDITIONS
 *LENGTHS AVAILABLE FROM 20 MM TPTD 250+MM

PERFORMANCE & MECHANICAL DATA

	STEEL THICKNESS	4.8 MM(#10)	5.5 MM(#12)	6.3 MM(#14)
SHEAR STRENGTH(N)		6700	10400	13400
TENSILE STRENGTH(N)		9500	13900	15500
TORSIONAL STRENGTH(N-M)		6.5	10.0	14.0
PULL OUT STRENGTH(N)	2.3MM	4690	4700	5000
	3.2MM	7480	7610	7930
	4.5MM	9680	12700	13500
	6.0MM		13900	15000
DRILLING CAPACITY	MAX.MM	3.5	4.5	6.0

MENTIONED VALUES ARE ULTIMATE PEAK LOADS AND DO NOT CONTAIN SAFETY FACTORS.

Test Certificate

MIS Tools Building Metal Products Trading LLC
Deira
Dubai
DUBAI
United Arab Emirates

Report Number D920958 : Issue 2
Page 1 of 1
Order Number D24-18482
Date Tested 22/10/24
Date Reported 23/10/24

Attn: Arbaaz Mukadam

Item - 4.5mm OD Self Drilling Screw

Specification - N/A

P.M.I. - Client Requirement			
	Position	Details	Comments
001:Lab XRF Analysis	Surface	Id'd As: SS 304	Cr% = 18.1 N1% = 8.32 Mo% = 0.04

Certificate Comments

*Testing conducted after removing the coating.

This is an electronically issued test certificate.

No Signature / Stamp is required.

Item/Description: Provided by the client.

----- End of Text -----

Tested by **AI Futtaim Element Dubai**



Al-Futtaim Element Materials Technology Dubai L.L.C.
PO Box 34924, Dubai, United Arab Emirates
T: +971 4 885 1001, +971 4 885 4004

Pratap Adiyodi
Operations Manager Metallurgy
For and on authority of
Al Futtaim Element Materials

TEST REPORT

No. :NBIN2509004693ML01_EN

Date : 2025-09-18

Page: 1 of 5



CUSTOMER NAME: MIS TOOLS BULIDING METAL PRODUCTS TRADING LLC
ADDRESS: W139 B,DUBAI MARITIME CITY,DUBAI,UAE

Sample Name : SCREWS
Product Specification : DIN 7504 5.5X80
Product or Lot No. : MIS-250427-04

Buyer : MIS TOOLS BULIDING METAL PRODUCTS TRADING LLC
Material and Mark : 304HC1/SWRCH22A
Heat No. : S240908AA15

Above information and sample(s) was/were submitted and confirmed by the client. SGS, however, assumes no responsibility to verify the accuracy, adequacy and completeness of the sample information provided by client.

Test Required : Tensile Test For Full-Size Fastener, Single Shear Test, Pull out Test
Date of Receipt : 2025-09-08
Testing Period : 2025-09-08 ~ 2025-09-18
Test result(s) : For further details, please refer to the following page(s)
(Unless otherwise stated the results shown in this test report refer only to the sample(s) tested)

Signed for
SGS-CSTC Standards Technical
Services Co., Ltd Ningbo Branch.

Reveka Chen

Reveka Chen
Authorized signatory



Unless otherwise agreed in writing, this document is issued by the Company subject to its General Conditions of Service printed overleaf, available on request or accessible at <https://www.sgs.com/en/Terms-and-Conditions>. Attention is drawn to the limitation of liability, indemnification and jurisdiction issues defined therein. Any holder of this document is advised that information contained hereon reflects the Company's findings at the time of its intervention only and within the limits of Client's instructions, if any. The Company's sole responsibility is to its Client and this document does not exonerate parties to a transaction from exercising all their rights and obligations under the transaction documents. This document cannot be reproduced except in full, without prior written approval of the Company. Any unauthorized alteration, forgery or falsification of the content or appearance of this document is unlawful and offenders may be prosecuted to the fullest extent of the law. Unless otherwise stated the results shown in this test report refer only to the sample(s) tested and such sample(s) are retained for 30 days only.

Attention: To check the authenticity of testing /inspection report & certificate, please contact us at telephone: (86-755) 8307 1443, or email: CN.Doccheck@sgs.com

No.1177, LingyunRoad, Hi-Tech Zone, Ningbo, Zhejiang, China 315040
中国·浙江·宁波高新区凌云路1177号 邮编: 315040

ML (86-574) 89070283 www.sgsgroup.com.cn
PL (86-574) 89070238 sgs.china@sgs.com

TEST REPORT

No. :NBIN2509004693ML01_EN

Date : 2025-09-18

Page: 2 of 5

1. Tensile Test For Full-Size Fastener

TestMethod:ASTMF606/F606M-25

Test item	Ultimate tensile load (kN)	Broken location
001	12.59	The free threaded length

Test photo:

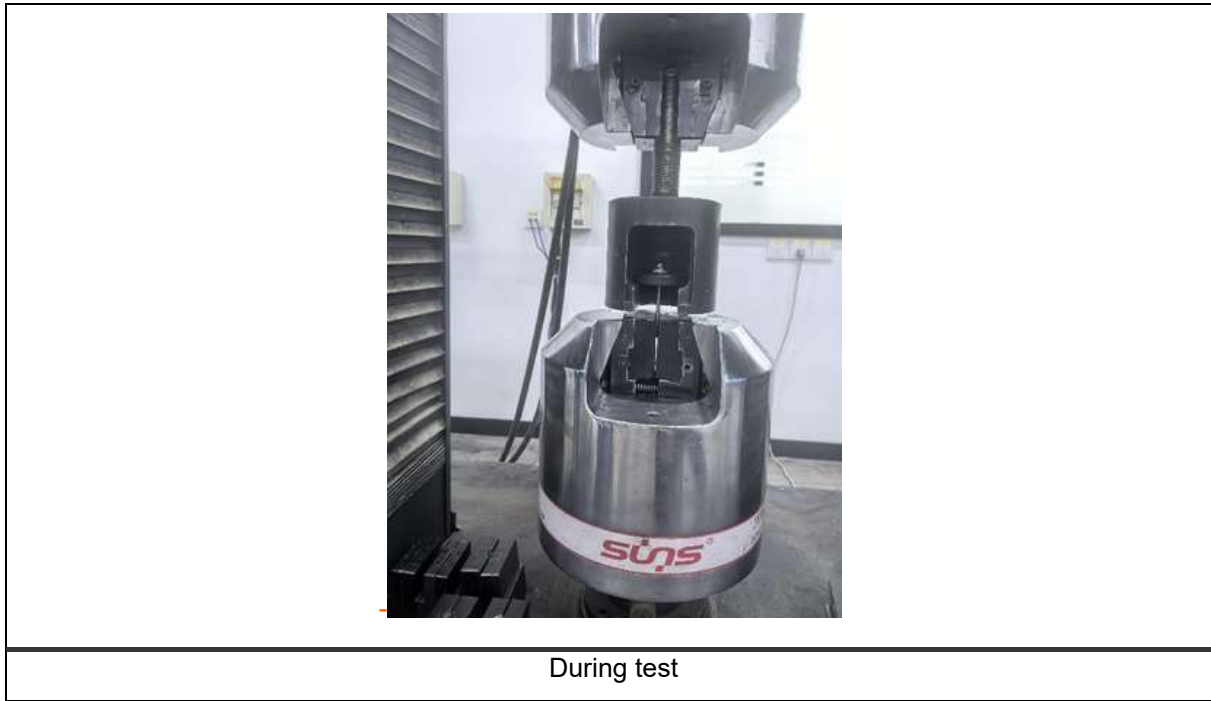

Unless otherwise agreed in writing, this document is issued by the Company subject to its General Conditions of Service printed overleaf, available on request or accessible at <https://www.sgs.com/en/Terms-and-Conditions>. Attention is drawn to the limitation of liability, indemnification and jurisdiction issues defined therein. Any holder of this document is advised that information contained hereon reflects the Company's findings at the time of its intervention only and within the limits of Client's instructions, if any. The Company's sole responsibility is to its Client and this document does not exonerate parties to a transaction from exercising all their rights and obligations under the transaction documents. This document cannot be reproduced except in full, without prior written approval of the Company. Any unauthorized alteration, forgery or falsification of the content or appearance of this document is unlawful and offenders may be prosecuted to the fullest extent of the law. Unless otherwise stated the results shown in this test report refer only to the sample(s) tested and such sample(s) are retained for 30 days only.

Attention: To check the authenticity of testing /inspection report & certificate, please contact us at telephone: (86-755) 8307 1443, or email: CN.Doccheck@sgs.com

SGS-CS Standards Technical Service Co., Ltd. No.1177, LingyunRoad, Hi-Tech Zone, Ningbo, Zhejiang, China 315040 ML (86-574) 89070283 www.sgsgroup.com.cn
 Ningbo Branch (China) 中国·浙江·宁波高新区凌云路1177号 邮编: 315040 PL (86-574) 89070238 sgs.china@sgs.com

TEST REPORT

No. :NBIN2509004693ML01_EN

Date : 2025-09-18

Page: 3 of 5

2. Single Shear Test

TestMethod:ASTMF606/F606M-25

Test item	Ultimate shear force (single section) (kN)
001	8.80

Test photo:

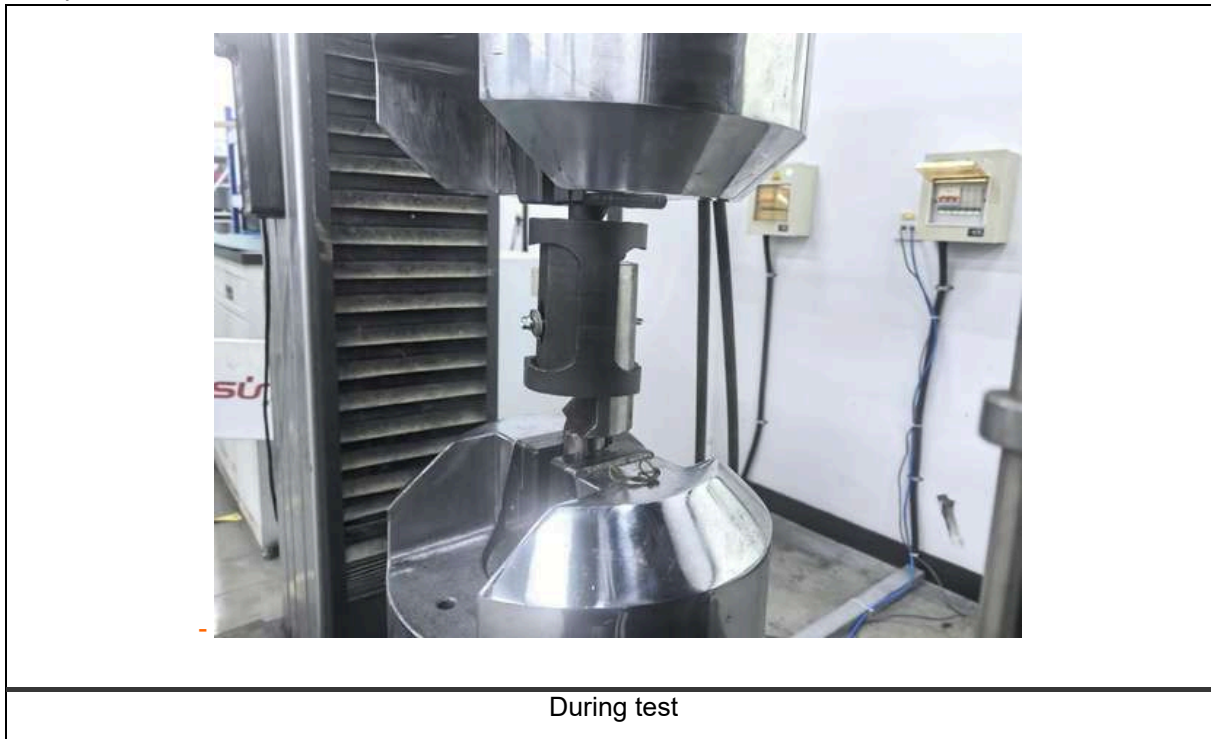

Unless otherwise agreed in writing, this document is issued by the Company subject to its General Conditions of Service printed overleaf, available on request or accessible at <https://www.sgs.com/en/Terms-and-Conditions>. Attention is drawn to the limitation of liability, indemnification and jurisdiction issues defined therein. Any holder of this document is advised that information contained hereon reflects the Company's findings at the time of its intervention only and within the limits of Client's instructions, if any. The Company's sole responsibility is to its Client and this document does not exonerate parties to a transaction from exercising all their rights and obligations under the transaction documents. This document cannot be reproduced except in full, without prior written approval of the Company. Any unauthorized alteration, forgery or falsification of the content or appearance of this document is unlawful and offenders may be prosecuted to the fullest extent of the law. Unless otherwise stated the results shown in this test report refer only to the sample(s) tested and such sample(s) are retained for 30 days only.

Attention: To check the authenticity of testing /inspection report & certificate, please contact us at telephone: (86-755) 8307 1443, or email: CN.Doccheck@sgs.com

No.1177, LingyunRoad, Hi-Tech Zone, Ningbo, Zhejiang, China 315040
 中国·浙江·宁波高新区凌云路1177号 邮编: 315040

ML (86-574) 89070283 www.sgs.com.cn
 PL (86-574) 89070238 sgs.china@sgs.com

TEST REPORT

No. :NBIN2509004693ML01_EN

Date : 2025-09-18

Page: 4 of 5

3. Pull out

Test Method: Per client s requirement.

Test result:

Test item	Maximum force (kN)	Fracture location
Result-001	6.47	Thread release

Test Photo:



During test



Unless otherwise agreed in writing, this document is issued by the Company subject to its General Conditions of Service printed overleaf, available on request or accessible at <https://www.sgs.com/en/Terms-and-Conditions>. Attention is drawn to the limitation of liability, indemnification and jurisdiction issues defined therein. Any holder of this document is advised that information contained hereon reflects the Company's findings at the time of its intervention only and within the limits of Client's instructions, if any. The Company's sole responsibility is to its Client and this document does not exonerate parties to a transaction from exercising all their rights and obligations under the transaction documents. This document cannot be reproduced except in full, without prior written approval of the Company. Any unauthorized alteration, forgery or falsification of the content or appearance of this document is unlawful and offenders may be prosecuted to the fullest extent of the law. Unless otherwise stated the results shown in this test report refer only to the sample(s) tested and such sample(s) are retained for 30 days only.

Attention: To check the authenticity of testing /inspection report & certificate, please contact us at telephone: (86-755) 8307 1443, or email: CN.Doccheck@sgs.com

SGS-CS Standards Technical Service Co., Ltd.
Ningbo Branch

No.1177, LingyunRoad, Hi-Tech Zone, Ningbo, Zhejiang, China 315040
中国·浙江·宁波高新区凌云路1177号 邮编: 315040

ML (86-574) 89070283 www.sgs.com.cn
PL (86-574) 89070238 sgs.china@sgs.com

TEST REPORT

No. :NBIN2509004693ML01_EN

Date : 2025-09-18

Page: 5 of 5

Sample Photo

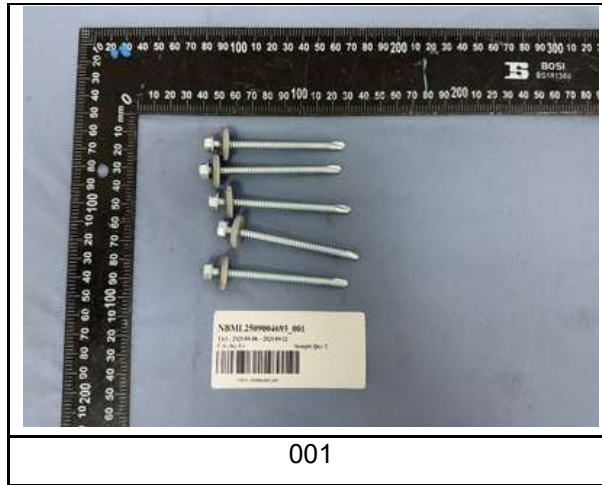

001

The test report shall only be used for clients scientific research, teaching, internal quality control, product research and development, etc and just for internal reference.

*****End of report*****



Unless otherwise agreed in writing, this document is issued by the Company subject to its General Conditions of Service printed overleaf, available on request or accessible at <https://www.sgs.com/en/Terms-and-Conditions>. Attention is drawn to the limitation of liability, indemnification and jurisdiction issues defined therein. Any holder of this document is advised that information contained hereon reflects the Company's findings at the time of its intervention only and within the limits of Client's instructions, if any. The Company's sole responsibility is to its Client and this document does not exonerate parties to a transaction from exercising all their rights and obligations under the transaction documents. This document cannot be reproduced except in full, without prior written approval of the Company. Any unauthorized alteration, forgery or falsification of the content or appearance of this document is unlawful and offenders may be prosecuted to the fullest extent of the law. Unless otherwise stated the results shown in this test report refer only to the sample(s) tested and such sample(s) are retained for 30 days only.

Attention: To check the authenticity of testing /inspection report & certificate, please contact us at telephone: (86-755) 8307 1443, or email: CN.Doccheck@sgs.com

SGS-CS Standards Technical Service Co., Ltd.
Ningbo Branch

No.1177, LingyunRoad, Hi-Tech Zone, Ningbo, Zhejiang, China 315040
中国·浙江·宁波高新区凌云路1177号 邮编: 315040

ML (86-574) 89070283 www.sgsgroup.com.cn
PL (86-574) 89070238 sgs.china@sgs.com

TEST REPORT

No. :NBIN2509004693ML02_EN

Date : 2025-09-18

Page: 1 of 5



CUSTOMER NAME: MIS TOOLS BULIDING METAL PRODUCTS TRADING LLC
ADDRESS: W139 B,DUBAI MARITIME CITY,DUBAI,UAE

Sample Name : SCREWS
Product Specification : DIN 7504 5.5X125
Product or Lot No. : MIS-250517-1
Manufacturer : HEBEI XILIDE
Buyer : MIS TOOLS BULIDING METAL PRODUCTS TRADING LLC
Material and Mark : 304HC1/SWRCH22A
Heat No. : S240908AA15

Above information and sample(s) was/were submitted and confirmed by the client. SGS, however, assumes no responsibility to verify the accuracy, adequacy and completeness of the sample information provided by client.

Test Required : Tensile Test For Full-Size Fastener,Single Shear Test,Pull out Test
Date of Receipt : 2025-09-08
Testing Period : 2025-09-08 ~ 2025-09-18
Test result(s) : For further details, please refer to the following page(s)
(Unless otherwise stated the results shown in this test report refer only to the sample(s) tested)

Signed for
SGS-CSTC Standards Technical
Services Co., Ltd Ningbo Branch.

Reveka Chen

Reveka Chen
Authorized signatory



Unless otherwise agreed in writing, this document is issued by the Company subject to its General Conditions of Service printed overleaf, available on request or accessible at <https://www.sgs.com/en/Terms-and-Conditions>. Attention is drawn to the limitation of liability, indemnification and jurisdiction issues defined therein. Any holder of this document is advised that information contained hereon reflects the Company's findings at the time of its intervention only and within the limits of Client's instructions, if any. The Company's sole responsibility is to its Client and this document does not exonerate parties to a transaction from exercising all their rights and obligations under the transaction documents. This document cannot be reproduced except in full, without prior written approval of the Company. Any unauthorized alteration, forgery or falsification of the content or appearance of this document is unlawful and offenders may be prosecuted to the fullest extent of the law. Unless otherwise stated the results shown in this test report refer only to the sample(s) tested and such sample(s) are retained for 30 days only.

Attention: To check the authenticity of testing /inspection report & certificate, please contact us at telephone: (86-755) 8307 1443, or email: CN.Doccheck@sgs.com

TEST REPORT

No. :NBIN2509004693ML02_EN

Date : 2025-09-18

Page: 2 of 5

1. Tensile Test For Full-Size Fastener

TestMethod:ASTMF606/F606M-25

Test item	Ultimate tensile load (kN)	Broken location
002	12.29	Unthreaded rod

Test photo:

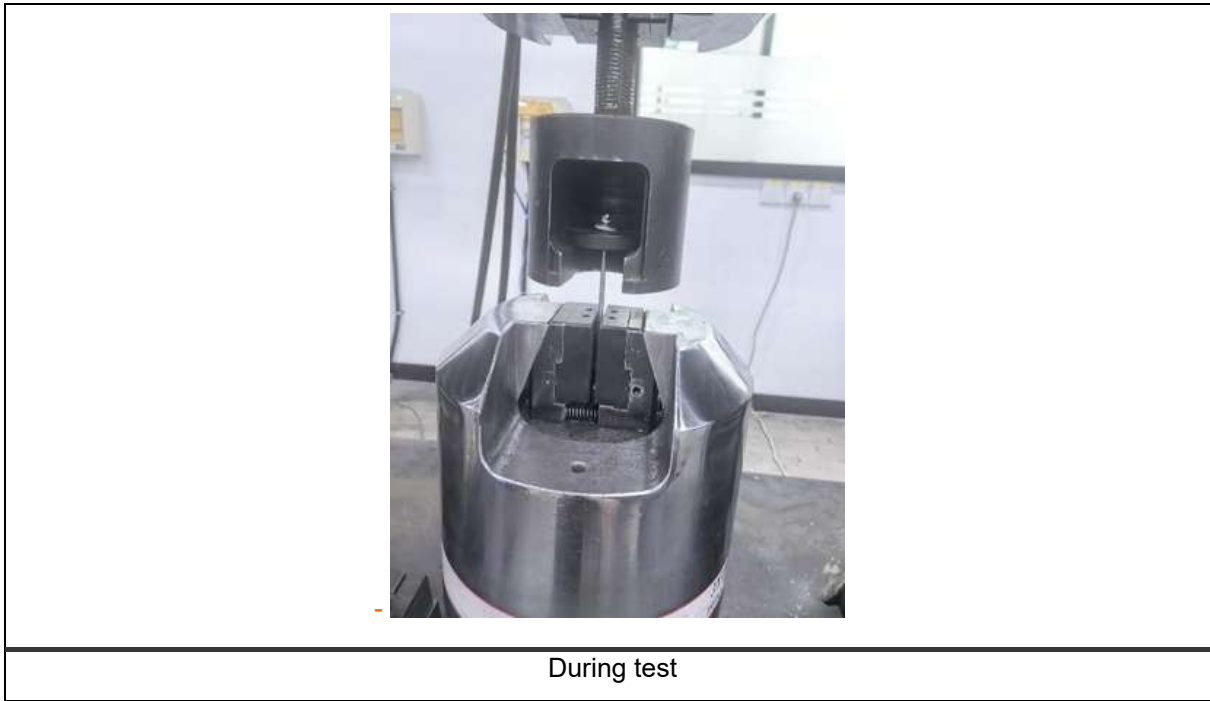

Unless otherwise agreed in writing, this document is issued by the Company subject to its General Conditions of Service printed overleaf, available on request or accessible at <https://www.sgs.com/en/Terms-and-Conditions>. Attention is drawn to the limitation of liability, indemnification and jurisdiction issues defined therein. Any holder of this document is advised that information contained hereon reflects the Company's findings at the time of its intervention only and within the limits of Client's instructions, if any. The Company's sole responsibility is to its Client and this document does not exonerate parties to a transaction from exercising all their rights and obligations under the transaction documents. This document cannot be reproduced except in full, without prior written approval of the Company. Any unauthorized alteration, forgery or falsification of the content or appearance of this document is unlawful and offenders may be prosecuted to the fullest extent of the law. Unless otherwise stated the results shown in this test report refer only to the sample(s) tested and such sample(s) are retained for 30 days only.

Attention: To check the authenticity of testing /inspection report & certificate, please contact us at telephone: (86-755) 8307 1443, or email: CN.Doccheck@sgs.com

TEST REPORT

No. :NBIN2509004693ML02_EN

Date : 2025-09-18

Page: 3 of 5

2. Single Shear Test

TestMethod:ASTMF606/F606M-25

Test item	Ultimate shear force (single section) (kN)
002	9.13

Test photo:

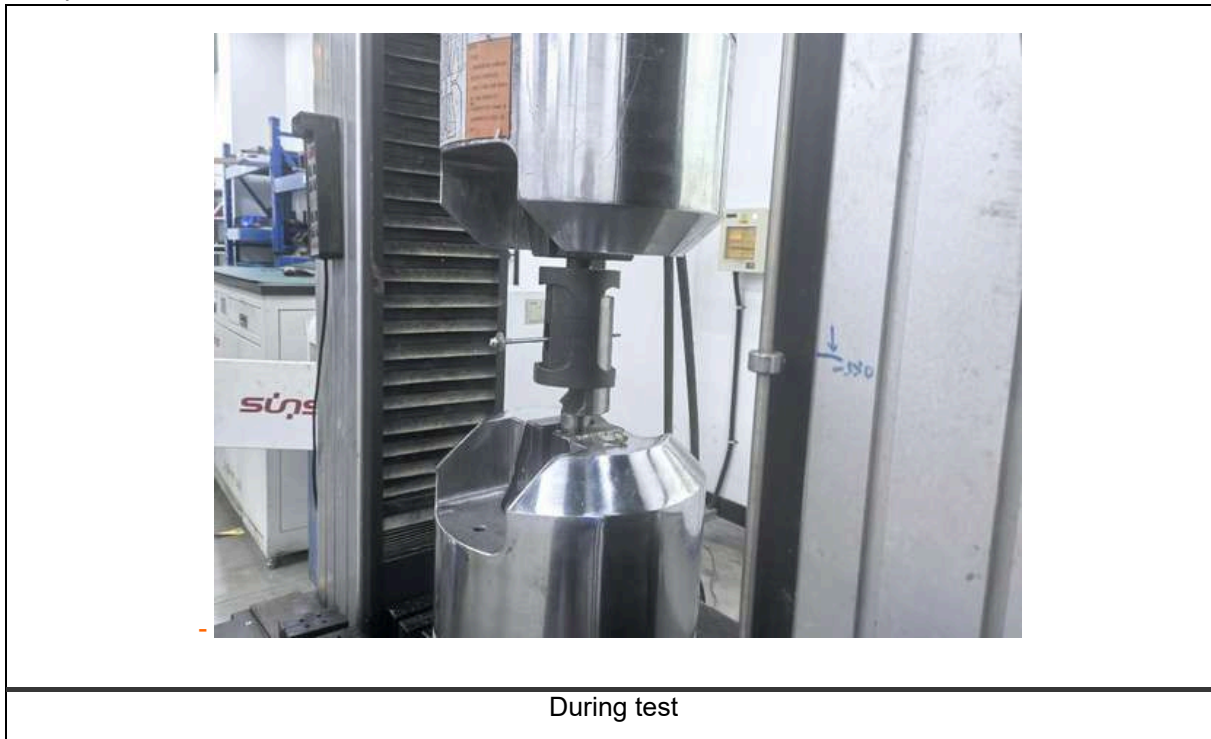

Unless otherwise agreed in writing, this document is issued by the Company subject to its General Conditions of Service printed overleaf, available on request or accessible at <https://www.sgs.com/en/Terms-and-Conditions>. Attention is drawn to the limitation of liability, indemnification and jurisdiction issues defined therein. Any holder of this document is advised that information contained hereon reflects the Company's findings at the time of its intervention only and within the limits of Client's instructions, if any. The Company's sole responsibility is to its Client and this document does not exonerate parties to a transaction from exercising all their rights and obligations under the transaction documents. This document cannot be reproduced except in full, without prior written approval of the Company. Any unauthorized alteration, forgery or falsification of the content or appearance of this document is unlawful and offenders may be prosecuted to the fullest extent of the law. Unless otherwise stated the results shown in this test report refer only to the sample(s) tested and such sample(s) are retained for 30 days only.

Attention: To check the authenticity of testing /inspection report & certificate, please contact us at telephone: (86-755) 8307 1443, or email: CN.Doccheck@sgs.com

TEST REPORT

No. :NBIN2509004693ML02_EN

Date : 2025-09-18

Page: 4 of 5

3. Pull out

Test Method: Per client s requirement.

Test result:

Test item	Maximum force (kN)	Fracture location
Result-002	6.29	Thread release

Test Photo:

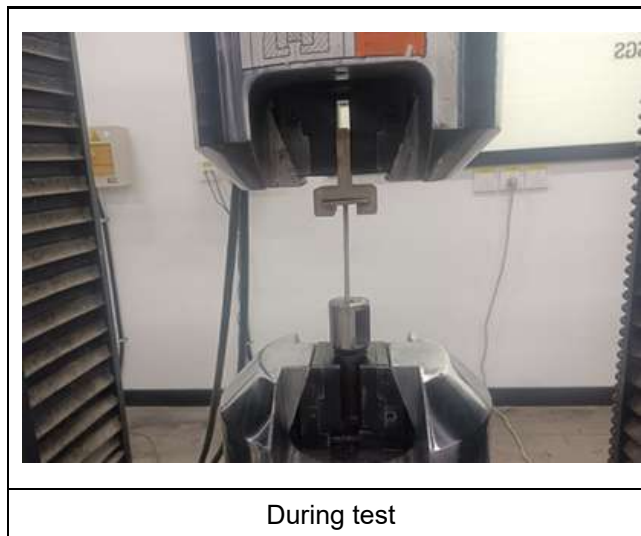

Unless otherwise agreed in writing, this document is issued by the Company subject to its General Conditions of Service printed overleaf, available on request or accessible at <https://www.sgs.com/en/Terms-and-Conditions>. Attention is drawn to the limitation of liability, indemnification and jurisdiction issues defined therein. Any holder of this document is advised that information contained hereon reflects the Company's findings at the time of its intervention only and within the limits of Client's instructions, if any. The Company's sole responsibility is to its Client and this document does not exonerate parties to a transaction from exercising all their rights and obligations under the transaction documents. This document cannot be reproduced except in full, without prior written approval of the Company. Any unauthorized alteration, forgery or falsification of the content or appearance of this document is unlawful and offenders may be prosecuted to the fullest extent of the law. Unless otherwise stated the results shown in this test report refer only to the sample(s) tested and such sample(s) are retained for 30 days only.

Attention: To check the authenticity of testing /inspection report & certificate, please contact us at telephone: (86-755) 8307 1443, or email: CN.Doccheck@sgs.com

SGS-CS (China) Technical Services Co., Ltd.
Ningbo Branch

No.1177, LingyunRoad, Hi-Tech Zone, Ningbo, Zhejiang, China 315040
中国·浙江·宁波高新区凌云路1177号 邮编: 315040

ML (86-574) 89070283 www.sgs.com.cn
PL (86-574) 89070238 sgs.china@sgs.com

TEST REPORT

No. :NBIN2509004693ML02_EN

Date : 2025-09-18

Page: 1 of 5



CUSTOMER NAME: MIS TOOLS BULIDING METAL PRODUCTS TRADING LLC
ADDRESS: W139 B,DUBAI MARITIME CITY,DUBAI,UAE

Sample Name : SCREWS
Product Specification : DIN 7504 5.5X125
Product or Lot No. : MIS-250517-1

Buyer : MIS TOOLS BULIDING METAL PRODUCTS TRADING LLC
Material and Mark : 304HC1/SWRCH22A
Heat No. : S240908AA15

Above information and sample(s) was/were submitted and confirmed by the client. SGS, however, assumes no responsibility to verify the accuracy, adequacy and completeness of the sample information provided by client.

Test Required : Tensile Test For Full-Size Fastener,Single Shear Test,Pull out Test
Date of Receipt : 2025-09-08
Testing Period : 2025-09-08 ~ 2025-09-18
Test result(s) : For further details, please refer to the following page(s)
(Unless otherwise stated the results shown in this test report refer only to the sample(s) tested)

Signed for
SGS-CSTC Standards Technical
Services Co., Ltd Ningbo Branch.

Reveka Chen

Reveka Chen
Authorized signatory



Unless otherwise agreed in writing, this document is issued by the Company subject to its General Conditions of Service printed overleaf, available on request or accessible at <https://www.sgs.com/en/Terms-and-Conditions>. Attention is drawn to the limitation of liability, indemnification and jurisdiction issues defined therein. Any holder of this document is advised that information contained hereon reflects the Company's findings at the time of its intervention only and within the limits of Client's instructions, if any. The Company's sole responsibility is to its Client and this document does not exonerate parties to a transaction from exercising all their rights and obligations under the transaction documents. This document cannot be reproduced except in full, without prior written approval of the Company. Any unauthorized alteration, forgery or falsification of the content or appearance of this document is unlawful and offenders may be prosecuted to the fullest extent of the law. Unless otherwise stated the results shown in this test report refer only to the sample(s) tested and such sample(s) are retained for 30 days only.

Attention: To check the authenticity of testing /inspection report & certificate, please contact us at telephone: (86-755) 8307 1443, or email: CN.Doccheck@sgs.com

TEST REPORT

No. :NBIN2509004693ML02_EN

Date : 2025-09-18

Page: 2 of 5

1. Tensile Test For Full-Size Fastener

TestMethod:ASTMF606/F606M-25

Test item	Ultimate tensile load (kN)	Broken location
002	12.29	Unthreaded rod

Test photo:

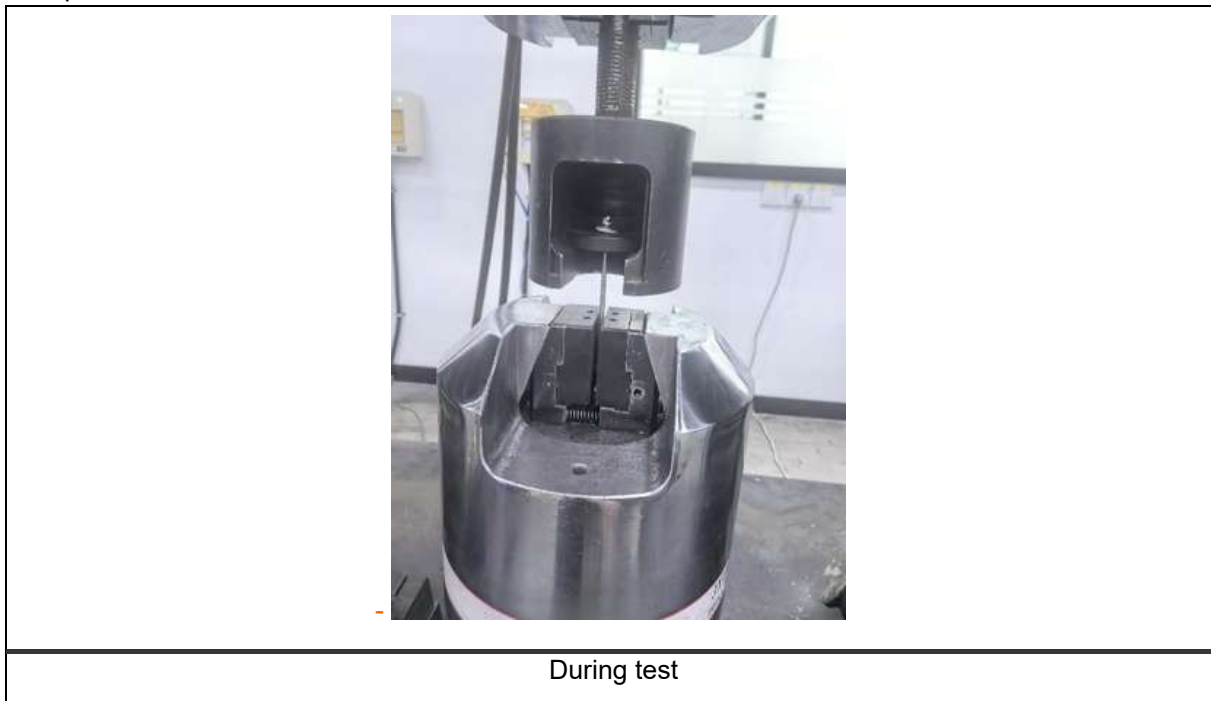

Unless otherwise agreed in writing, this document is issued by the Company subject to its General Conditions of Service printed overleaf, available on request or accessible at <https://www.sgs.com/en/Terms-and-Conditions>. Attention is drawn to the limitation of liability, indemnification and jurisdiction issues defined therein. Any holder of this document is advised that information contained hereon reflects the Company's findings at the time of its intervention only and within the limits of Client's instructions, if any. The Company's sole responsibility is to its Client and this document does not exonerate parties to a transaction from exercising all their rights and obligations under the transaction documents. This document cannot be reproduced except in full, without prior written approval of the Company. Any unauthorized alteration, forgery or falsification of the content or appearance of this document is unlawful and offenders may be prosecuted to the fullest extent of the law. Unless otherwise stated the results shown in this test report refer only to the sample(s) tested and such sample(s) are retained for 30 days only.

Attention: To check the authenticity of testing /inspection report & certificate, please contact us at telephone: (86-755) 8307 1443, or email: CN.Doccheck@sgs.com

SGS-CS (China) Technical Services Co., Ltd.
Ningbo Branch (Inspection & Testing Services)

No.1177, LingyunRoad, Hi-Tech Zone, Ningbo, Zhejiang, China 315040
中国·浙江·宁波高新区凌云路1177号 邮编: 315040

ML (86-574) 89070283 www.sgs.com.cn
PL (86-574) 89070238 sgs.china@sgs.com

TEST REPORT

No. :NBIN2509004693ML02_EN

Date : 2025-09-18

Page: 3 of 5

2. Single Shear Test

TestMethod:ASTMF606/F606M-25

Test item	Ultimate shear force (single section) (kN)
002	9.13

Test photo:

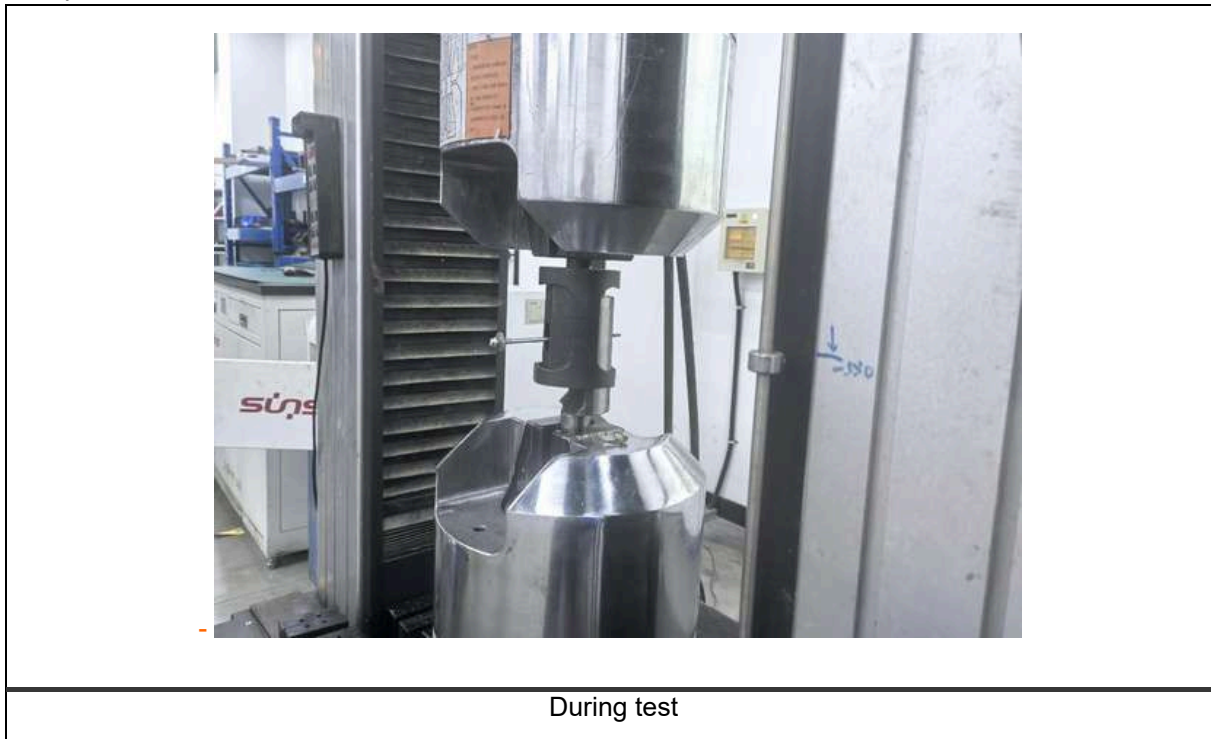

Unless otherwise agreed in writing, this document is issued by the Company subject to its General Conditions of Service printed overleaf, available on request or accessible at <https://www.sgs.com/en/Terms-and-Conditions>. Attention is drawn to the limitation of liability, indemnification and jurisdiction issues defined therein. Any holder of this document is advised that information contained hereon reflects the Company's findings at the time of its intervention only and within the limits of Client's instructions, if any. The Company's sole responsibility is to its Client and this document does not exonerate parties to a transaction from exercising all their rights and obligations under the transaction documents. This document cannot be reproduced except in full, without prior written approval of the Company. Any unauthorized alteration, forgery or falsification of the content or appearance of this document is unlawful and offenders may be prosecuted to the fullest extent of the law. Unless otherwise stated the results shown in this test report refer only to the sample(s) tested and such sample(s) are retained for 30 days only.

Attention: To check the authenticity of testing /inspection report & certificate, please contact us at telephone: (86-755) 8307 1443, or email: CN.Doccheck@sgs.com

TEST REPORT

No. :NBIN2509004693ML02_EN

Date : 2025-09-18

Page: 4 of 5

3. Pull out

Test Method: Per client s requirement.

Test result:

Test item	Maximum force (kN)	Fracture location
Result-002	6.29	Thread release

Test Photo:

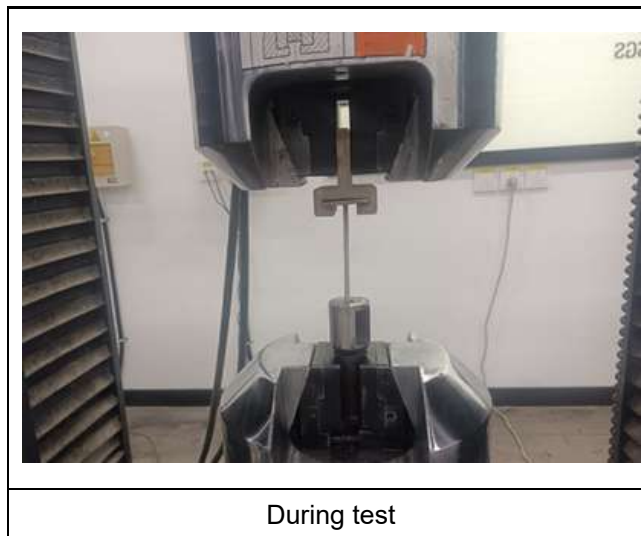

During test



Unless otherwise agreed in writing, this document is issued by the Company subject to its General Conditions of Service printed overleaf, available on request or accessible at <https://www.sgs.com/en/Terms-and-Conditions>. Attention is drawn to the limitation of liability, indemnification and jurisdiction issues defined therein. Any holder of this document is advised that information contained hereon reflects the Company's findings at the time of its intervention only and within the limits of Client's instructions, if any. The Company's sole responsibility is to its Client and this document does not exonerate parties to a transaction from exercising all their rights and obligations under the transaction documents. This document cannot be reproduced except in full, without prior written approval of the Company. Any unauthorized alteration, forgery or falsification of the content or appearance of this document is unlawful and offenders may be prosecuted to the fullest extent of the law. Unless otherwise stated the results shown in this test report refer only to the sample(s) tested and such sample(s) are retained for 30 days only.

Attention: To check the authenticity of testing /inspection report & certificate, please contact us at telephone: (86-755) 8307 1443, or email: CN.Doccheck@sgs.com

SGS-CSI Standards Technical Services Co., Ltd.
Ningbo Branch

No.1177, LingyunRoad, Hi-Tech Zone, Ningbo, Zhejiang, China 315040
中国·浙江·宁波高新区凌云路1177号 邮编: 315040

ML (86-574) 89070283 www.sgs.com.cn
PL (86-574) 89070238 sgs.china@sgs.com

TEST REPORT

No. :NBIN2509004693ML02_EN

Date : 2025-09-18

Page: 5 of 5

Sample Photo



The test report shall only be used for clients scientific research, teaching, internal quality control, product research and development, etc and just for internal reference.

*****End of report*****



Unless otherwise agreed in writing, this document is issued by the Company subject to its General Conditions of Service printed overleaf, available on request or accessible at <https://www.sgs.com/en/Terms-and-Conditions>. Attention is drawn to the limitation of liability, indemnification and jurisdiction issues defined therein. Any holder of this document is advised that information contained hereon reflects the Company's findings at the time of its intervention only and within the limits of Client's instructions, if any. The Company's sole responsibility is to its Client and this document does not exonerate parties to a transaction from exercising all their rights and obligations under the transaction documents. This document cannot be reproduced except in full, without prior written approval of the Company. Any unauthorized alteration, forgery or falsification of the content or appearance of this document is unlawful and offenders may be prosecuted to the fullest extent of the law. Unless otherwise stated the results shown in this test report refer only to the sample(s) tested and such sample(s) are retained for 30 days only.

Attention: To check the authenticity of testing /inspection report & certificate, please contact us at telephone: (86-755) 8307 1443, or email: CN.Doccheck@sgs.com

SGS-CTE Technical Services Co., Ltd.
Ningbo Branch

No.1177, LingyunRoad, Hi-Tech Zone, Ningbo, Zhejiang, China 315040
中国·浙江·宁波高新区凌云路1177号 邮编: 315040

ML (86-574) 89070283 www.sgs.com.cn
PL (86-574) 89070238 sgs.china@sgs.com

SAMPLE SALT SPRAY TEST REPORT

1500 HOURS RUSPERT COATING



中国认可
国际互认
检测
TESTING
CNAS L4305

TEST REPORT

No.: NBIN2601000202PL04-1_EN

IssueDate: 2026-01-29

Page : 1 of 3

CUSTOMER NAME: MIS TOOLS BUILDING METAL PRODUCTS TRADING LLC
ADDRESS: W139, DUBAI MARITIME CITY, DUBAI

Sample Name : SELF DRILLING SCREW
Product Specification : 5.5X 150 SS304 Sd SCREW RUSPERT 1500H
Product or Lot No. : MIS-25111601-01
Manufacturer :
Buyer : MIS TOOLS BUILDING METAL PRODUCTS
Material : SS304

Above information and sample(s) was/were submitted and confirmed by the client. SGS, however, assumes no responsibility to verify the accuracy, adequacy and completeness of the sample information provided by client.

SGS Ref. No. : NBIN2601000352ML04
Date of Receipt : 2026-01-20
Testing Period : 2026-01-20 ~ 2026-01-23
Test result(s) : For further details, please refer to the following page(s)
(Unless otherwise stated the results shown in this test report refer only to the sample(s) tested)

Signed for and on behalf of
SGS-CSTC Standards Technical Services (Ningbo) Co., Ltd.

July Zhang

July Zhang

Authorized signatory



Unless otherwise agreed in writing, this document is issued by the Company subject to its General Conditions of Service printed overleaf, available on request or accessible at <https://www.sgs.com/en/Terms-and-Conditions>. Attention is drawn to the limitation of liability, indemnification and jurisdiction issues defined therein. Any holder of this document is advised that information contained hereon reflects the Company's findings at the time of its intervention only and within the limits of Client's instructions, if any. The Company's sole responsibility is to its Client and this document does not exonerate parties to a transaction from exercising all their rights and obligations under the transaction documents. This document cannot be reproduced except in full, without prior written approval of the Company. Any unauthorized alteration, forgery or falsification of the content or appearance of this document is unlawful and offenders may be prosecuted to the fullest extent of the law. Unless otherwise stated the results shown in this test report refer only to the sample(s) tested and such sample(s) are retained for 30 days only.

Attention: To check the authenticity of testing /inspection report & certificate, please contact us at telephone: (86-755) 8307 1443, or email: CN.Doccheck@sgs.com

SGS-CSTC Standards Technical Services (Ningbo) Co., Ltd.
Materials Laboratory

Unit 6 on 1F & Unit 2 on 2F of Building 7, 1F & Unit 2 on 4F of Building 5, Unit 2 on 1F & 2F on 3F of Building 4, Unit 2 on 1F of Building 3, No. 1177, Lingyuan Road, Hi-Tech Zone, Ningbo, Zhejiang, China. 315040 ML (86-574) 89070283 www.sgs.com.cn
中国·浙江·宁波高新区凌云路1177号001幢3层4区, 001幢4层1区 4区-4层, 001幢7层1区 4区-2层区 邮编: 315040 PL (86-574) 89070238 sgs.china@sgs.com

TEST REPORT

No.: NBIN2601000202PL04-1_EN

IssueDate: 2026-01-29

Page: 2 of 3

Summary of Results:

No.	Test Item	Test Method	Result	Conclusion
1	Neutral Salt Spray (NSS) Test	ASTM B117-19	See test result	Pass

Note: Pass : Meet the requirements;
 Fail : Does not meet the requirements;
 / : Not Apply to the judgment.

Original Sample Photo:

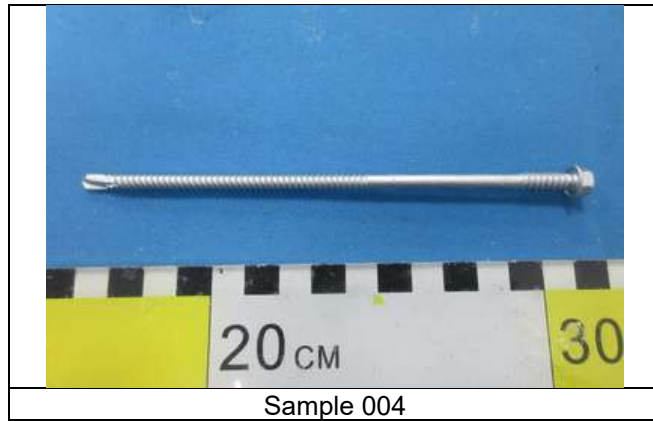

Unless otherwise agreed in writing, this document is issued by the Company subject to its General Conditions of Service printed overleaf, available on request or accessible at <https://www.sgs.com/en/Terms-and-Conditions>. Attention is drawn to the limitation of liability, indemnification and jurisdiction issues defined therein. Any holder of this document is advised that information contained hereon reflects the Company's findings at the time of its intervention only and within the limits of Client's instructions, if any. The Company's sole responsibility is to its Client and this document does not exonerate parties to a transaction from exercising all their rights and obligations under the transaction documents. This document cannot be reproduced except in full, without prior written approval of the Company. Any unauthorized alteration, forgery or falsification of the content or appearance of this document is unlawful and offenders may be prosecuted to the fullest extent of the law. Unless otherwise stated the results shown in this test report refer only to the sample(s) tested and such sample(s) are retained for 30 days only.

Attention: To check the authenticity of testing /inspection report & certificate, please contact us at telephone: (86-755) 8307 1443, or email: CN.Doccheck@sgs.com

SGS-CSTC (Shanghai) Technical Service Co., Ltd. | Unit 6 in 1F & Unit 2 in 2F of Building 7, 1F & Unit 2 in 4F of Building 5, Unit 2 in 1F & 2F in 3F of Building 4, Unit 2 in 1F of Building 3, No. 1177, Lingyun Road, Hi-Tech Zone, Ningbo, Zhejiang, China. 315040 ML (86-574) 89070283 www.sgs.com.cn
 中国·浙江·宁波高新区凌云路1177号003幢3层4区, 009幢4层4区 & 2区-5层, 008幢3层4区 & 4区及, 008幢3层4区 & 2区及 邮编: 315040 PL (86-574) 89070238 sgs.china@sgs.com

TEST REPORT

No.: NBIN2601000202PL04-1_EN

IssueDate: 2026-01-29

Page: 3 of 3

Test Item: Neutral Salt Spray (NSS) Test

Sample Description: Metal part

Test Method: ASTM B117-19

Test Condition:

Concentration of solution collected: (5±1)% NaCl(m/m)

Chamber temperature: (35±2)

Volume of salt solution collected: (1.0~2.0)ml/(80cm²·h)

pH of collected solution at (23±3)°C: 6.5~7.2

Exposure period: 48h

Test Result:

Test Item	Sample	Appearance	Client's requirement	Conclusion
Neutral Salt Spray (NSS) Test	1#	No visible change.	No red rust	Pass
	2#	No visible change.		Pass

Test Photo:

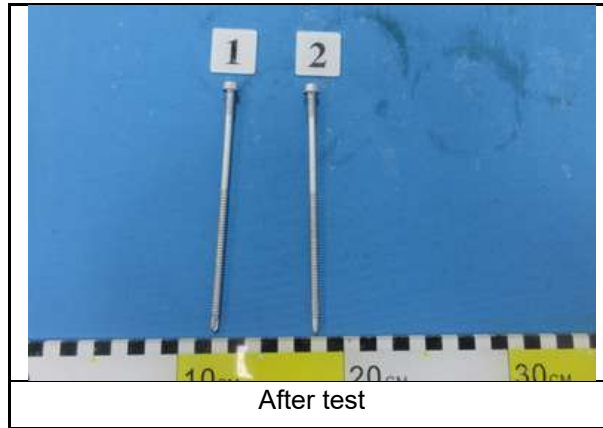

Equipment Information:

Equipment	Model	Equipment No.	Calibration date	Next Calibration date
Salt Spray Test Chamber	Q-FOG/CCT 1100	NBPL-A019	2025-03-26	2026-03-25

- The test report shall only be used for clients' scientific research, teaching, internal quality control, product research and development, etc... and just for internal reference.

This test report updates Home page information, supersedes the test report No. NBIN2601000202PL04_EN dated Jan 23rd, 2026, original report will be invalid from today.

*****End of report*****



Unless otherwise agreed in writing, this document is issued by the Company subject to its General Conditions of Service printed overleaf, available on request or accessible at <https://www.sgs.com/en/Terms-and-Conditions>. Attention is drawn to the limitation of liability, indemnification and jurisdiction issues defined therein. Any holder of this document is advised that information contained hereon reflects the Company's findings at the time of its intervention only and within the limits of Client's instructions, if any. The Company's sole responsibility is to its Client and this document does not exonerate parties to a transaction from exercising all their rights and obligations under the transaction documents. This document cannot be reproduced except in full, without prior written approval of the Company. Any unauthorized alteration, forgery or falsification of the content or appearance of this document is unlawful and offenders may be prosecuted to the fullest extent of the law. Unless otherwise stated the results shown in this test report refer only to the sample(s) tested and such sample(s) are retained for 30 days only.

Attention: To check the authenticity of testing /inspection report & certificate, please contact us at telephone: (86-755) 8307 1443, or email: CN.Doccheck@sgs.com

Unit 6 in 1F & Unit 2 in 2F of Building 7, 1F & Unit 2 in 4F of Building 5, Unit 2 in 1F & 2F in 3F of Building 4, Unit 2 in 1F of Building 3, No. 1177, Longren Road, Hi-Tech Zone, Ningbo, Zhejiang, China. 315040 ML (86-574) 89070283 www.sgs.com.cn
 中国·浙江·宁波高新区凌云路1177号001幢3层4区、009幢4层4区、008幢4层4区、008幢4层4区、008幢4层4区 邮编: 315040 PL (86-574) 89070238 sgs.china@sgs.com



MIS TOOLS BUILDING METAL PRODUCTS TRADING LLC

Bi-Metal SDS CORROSION WARRANTY

ENVIRONMENTAL CONDITIONS	CLASS 3 (1000HRS)	CLASS 4 (1500HRS)
<p>VERY SEVERE MARINE (ISO 9223 CATEGORY 5) Up to 400m from the ocean, but outside the ocean spray zone.</p>	NOT RECOMMENDED	NOT RECOMMENDED
<p>SEVERE MARINE (ISO 9223 CATEGORY 4) Between 400m and 1km from the ocean or within 150m from a salt water inlet or creek.</p>	NOTRECOMMENDED	10 years
<p>MILD & MODERATE MARINE (ISO 9223 CATEGORY 3) Between 1km and 50km from the ocean, or from 150m to 1km from a salt water inlet or creek.</p>	10 years	15 years
<p>SEVERE INDUSTRIAL (ISO 9223 CATEGORY 4) Within 2km of an industrial plant, sewerage treatment or airport.</p>	NOT RECOMMENDED	15 years
<p>INDUSTRIAL (ISO 9223 CATEGORY 3) Between 2km and 10km from an industrial plant, sewerage treatment or airport.</p>	20 years	25 years
<p>LIGHT INDUSTRIAL URBAN (ISO 9223 CATEGORY 2) All other regions not defined above.</p>	30 years	40 years

TECHNICAL DATASHEETS AND TEST REPORTS

SHEAR STUDS

TECHNICAL DATASHEET

SHEAR STUDS/CONNECTORS

1. APPLICATION

STRUCTURAL CONNECTION BETWEEN STEEL BEAMS AND CONCRETE SLABS IN COMPOSITE CONSTRUCTION, INCLUDING:

- COMPOSITE BEAMS IN BUILDING CONSTRUCTION
- BRIDGE DECKS
- INDUSTRIAL FLOORS AND PARKING STRUCTURES
- SHEAR WALLS AND SEISMIC SYSTEMS

2. STANDARDS COMPLIANCE

STANDARD	TITLE / SCOPE
ASTM A1044	STANDARD SPECIFICATION FOR STEEL BAR, CARBON AND ALLOY, COLD-FINISHED STANDARD SPECIFICATION FOR STEEL STUD ASSEMBLIES FOR SHEAR REINFORCEMENT OF CONCRETE
ASTM A1044	STANDARD SPECIFICATION FOR STEEL STUD ASSEMBLIES FOR SHEAR REINFORCEMENT OF CONCRETE
BS EN ISO 13918	WELDING - STUDS AND CERAMIC FERRULES FOR ARC STUD WELDING
BS 5950-3.1	STRUCTURAL USE OF STEELWORK IN BUILDING - DESIGN IN COMPOSITE CONSTRUCTION
BS EN 1994-1-1	EUROCODE 4: DESIGN OF COMPOSITE STEEL AND CONCRETE STRUCTURES

3. MATERIAL SPECIFICATION

3.1 BASE MATERIAL:

- LOW-CARBON STEEL PER ASTM A108 GRADE 1018/1020 OR EQUIVALENT
- EQUIVALENT TO BS EN 10025 S275 OR S355 GRADES

3.2 MECHANICAL PROPERTIES:

PROPERTY	ASTM REQUIREMENTS	BS/EN REQUIREMENTS
YIELD STRENGTH (MIN)	345 MPA (50 KSI) 350 MPA	
TENSILE STRENGTH (MIN)	415 MPA (60 KSI) 450-650 MPA	
ELONGATION (MIN)	20% 14%	
HARDNESS (MAX)	82 HRB	NOT SPECIFIED

3.3 CONDITION: SUPPLIED IN AS-WELDED CONDITION AFTER ARC STUD WELDING



SHEARSTUDS

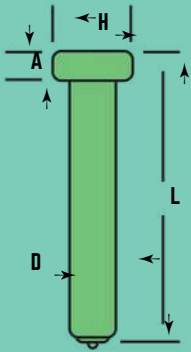

SHEAR CONNECTOR STUDS ARE DESIGNED TO TIE THE CONCRETE TO THE STEEL BEAMS AND TO RESIST SHEAR LOADINGS BETWEEN THE CONCRETE SLAB AND STEEL BEAM IN COMPOSITE CONSTRUCTION.

LENGTH: LENGTH IS BEFORE WELD. THE SHEAR CONNECTOR STUDS, WHEN WELDED TO BASE METAL WILL BE APPROXIMATELY 5MM SHORTER AFTER WELD AND WHEN WELDED THROUGH DECK 10MM SHORTER AFTER WELD. LENGTHS FOR SHEAR CONNECTOR STUDS ARE GENERALLY SET BY GOVERNING SPECIFICATIONS. ASK A SHEARSTUD LTD REPRESENTATIVE FOR OTHER LENGTHS AVAILABLE FOR SPECIFIC APPLICATIONS. MADE TO ORDER LENGTHS ARE AVAILABLE UPON REQUEST.

SPECIFICATION	DIAMETER	LENGTH	STRAIGHT TO STEEL LENGTH AFTER WELD	THRU DECK LENGTH AFTER WELD	A	H	FERRULE TYPE
BS EN ISO 13918	13 MM	80 MM	75 MM		8 MM	25 MM	STRAIGHT TO STEEL
		105 MM	100 MM		8 MM	25 MM	
		130 MM	125 MM		8 MM	25 MM	
		155 MM	150 MM		8 MM	25 MM	
		180 MM	175 MM		8 MM	25 MM	
		205 MM	200 MM		8 MM	25 MM	
		80 MM			8 MM	32 MM	
BS EN ISO 13918	16 MM	105 MM	75 MM		8 MM	32 MM	STRAIGHT TO STEEL
		130 MM	100 MM		8 MM	32 MM	
		155 MM	125 MM		8 MM	32 MM	
		180 MM	150 MM		8 MM	32 MM	
		205 MM	175 MM		8 MM	32 MM	
		200 MM					
BS 5400 6	19 MM	80 MM	75 MM	70 MM	10 MM	32 MM	THRU DECK OR
BS EN ISO 13918		105 MM	100 MM	95 MM	10 MM	32 MM	STRAIGHT TO STEEL
		130 MM	125 MM	120 MM	10 MM	32 MM	
		155 MM	150 MM	145 MM	10 MM	32 MM	
		180 MM	175 MM	170 MM	10 MM	32 MM	
		205 MM	200 MM	195 MM	10 MM	32 MM	
BS 5400 6	22 MM	105 MM	100 MM		10 MM	35 MM	STRAIGHT TO STEEL
BS EN ISO 13918		130 MM	125 MM		10 MM	35 MM	
		155 MM	150 MM		10 MM	35 MM	
		180 MM	175 MM		10 MM	35 MM	
		205 MM	200 MM		10 MM	35 MM	
BS 5400 6	25 MM	105 MM	100 MM		13 MM	41 MM	STRAIGHT TO STEEL
BS EN ISO 13918		130 MM	125 MM		13 MM	41 MM	
		155 MM	150 MM		13 MM	41 MM	
		180 MM	175 MM		13 MM	41 MM	
		205 MM	200 MM		13 MM	41 MM	
TENSILE TEST BS EN 10002-1:2001 SPECIFICATION			YIELD STRENGTH MIN	TENSILE STRENGTH MIN			ELONGATION MIN
BS EN ISO 13918:1998 SPECIFICATION			350	450			15%
BS 5400			385	495			15%

ALL VALUES ARE DESIGN AND INDICATIVE ONLY

5. MECHANICAL PERFORMANCE

5.1 DESIGN SHEAR RESISTANCE:

- CALCULATED ACCORDING TO BS 5950-3.1 OR EN 1994-1-1
- GOVERNED BY EITHER STUD STRENGTH OR CONCRETE STRENGTH (WHICHEVER IS LOWER)

5.2 CHARACTERISTIC RESISTANCE (PRD):

- FOR SOLID SLABS: $P_{RD} = \min[0.8F_u(\pi d^2/4)/\gamma_v, 0.29\alpha d^2\sqrt{f_{ck}E_{cm}}/\gamma_v]$
- WHERE:
- (F_u) = ULTIMATE TENSILE STRENGTH OF STUD
- (f_{ck}) = CHARACTERISTIC CONCRETE STRENGTH
- (γ_v) = PARTIAL SAFETY FACTOR (TYPICALLY 1.25)
- (α) = FACTOR FOR STUD HEIGHT/DIAMETER RATIO

5.3 TYPICAL DESIGN CAPACITIES (FOR C30/37 CONCRETE):

STUD DIAMETER	APPROX. DESIGN SHEAR CAPACITY
---------------	-------------------------------

13 MM	50-60 KN
16 MM	80-95 KN
19 MM	115-135 KN
22 MM	155-180 KN
25 MM	200-235 KN

NOTE: VALUES ARE INDICATIVE - ACTUAL CAPACITIES DEPEND ON CONCRETE GRADE AND STUD HEIGHT

8.1 MATERIAL CERTIFICATION: **

- MILL CERTIFICATES PER ASTM A108 OR BS EN 10025
- CHEMICAL COMPOSITION REPORT
- MECHANICAL PROPERTIES CERTIFICATE

8.2 PRODUCTION TESTING (PER BATCH):**



TECHNICAL DATASHEET: CERAMIC FERRULES FOR SHEAR STUDS

PRODUCT: SINGLE-USE CERAMIC FERRULES FOR DRAWN ARC STUD WELDING OF SHEAR CONNECTORS.

FUNCTION: CONTAIN MOLTEN METAL, SHAPE WELD FILLET, SHIELD ARC, PROTECT OPERATOR.

STANDARD: ISO 13918 COMPLIANT.

SPECIFICATIONS

STUD DIAMETER	FERRULE CODE	HEIGHT (≈)	OD (≈)	MIN. STUD LENGTH*
13 MM (1/2")	CF-13	25 MM	32 MM	75 MM
16 MM (5/8")	CF-16	28 MM	38 MM	80 MM
19 MM (3/4")	CF-19	32 MM	44 MM	100 MM
22 MM (7/8")	CF-22	35 MM	48 MM	100 MM
25 MM (1")	CF-25	40 MM	55 MM	125 MM

*FOR PROPER CHUCKING. CONSULT STUD MANUFACTURER.



MATERIAL: REFRACTORY CERAMIC (ALUMINA-SILICATE).

COLOR: TYPICALLY WHITE.

FEATURES: PRE-SCORED BREAK RIDGE, INTERNAL FILLET CAVITY, GAS VENTS.

TEMP. RESISTANCE: >1500°C (SHORT TERM).

MATERIAL TEST REPORT (Page 1 of 2)

Client	M/s, MIS Tools Building Metal Products Trading LLC	Report No.	PHY-100519
Location/Contact	Dubai, UAE	Report Date	03/02/2026
Contract	-	File/Task No.	-
Attention to	Mr. Shadab	Specimen No	75073
Receipt Date.	26/01/2026	Date Tested	03/02/2026

Sample Details

Size	SHEAR STUD M19X105	Grade	ASTM A108 Gr.C1010 -C 1020	Heat No	-
Other Details	-				

Tensile Test

Machine Type	UTM		Serial No	51301002
Test Method	ASTM A370 Ed:2024a			
Procedure No.	ITI/SOP01/Rev.10		Required	Actual
Dimension, mm	Ø 12.55	Area, mm ²	-	123.70
Yield Load, kN	46.51	Yield Strength, MPa	350min	376
Ultimate Tensile Load, kN	72.75	Ultimate Tensile Strength, MPa	450min	588
Initial Gage Length, mm	50.00	Final Gage Length, mm	-	60.25
% Elongation, 20min	21	% Reduction of Area	50min	58
Final Diameter, mm	8.10	-	-	-

Charpy 2mm V-Notch Impact Test -N/A

Test Method			Procedure No	
Machine Type			Serial No	
Dimension, mm			Location	
Orientation			Temperature	
Sample details	Specimen A	Specimen B	Specimen C	Average
Energy Absorbed Joules	-	-	-	-



MATERIAL TEST REPORT (Page 2 of 2)(PHY-100519)

CHEMICAL ANALYSIS

Test Method	ASTM E415 Ed:2021				Procedure No	ITI/SOP08/Rev.02	
Machine Type	OES				Serial No	22011846	
Element	C	Si	Mn	P	S	Cu	Al
Wt%	0.192	0.099	0.757	0.013	0.006	0.006	0.033
Requirement %	0.15-0.20	0.10max	0.60-0.90	0.030max	0.035max	-	0.02min



Remarks:The Sample tested above meets the requirement of ASTM A108 Gr.C1010-C1020

Tested By	Authorized By	Witnessed/Client
Name: Jenifer	Name:	
Designation:	Designation:	
Signature: 	Signature: 	
Date: 03/02/2026	Date: 03/02/2026	Date: 03/02/2026

F/ITI-LR/12-Issue 02 Rev.01

End of Report

Issue Date: 03/08/2020

This report pertaining to the provided sample tested & shall not be reproduced without prior written permission from ITI Dubai.
 This report is invalid without ITI Official Stamp & Signature.

MATERIAL TEST REPORT (Page 1 of 2)

Client	M/s, MIS Tools Building Metal Products Trading LLC	Report No.	PHY-100520
Location/Contact	Dubai, UAE	Report Date	03/02/2026
Contract	-	File/Task No.	-
Attention to	Mr. Shadab	Specimen No	75074
Receipt Date.	26/01/2026	Date Tested	03/02/2026

Sample Details

Size	SHEAR STUD M22X105	Grade	ASTM A108 Gr.C1010 -C 1020	Heat No	-
Other Details	-				

Tensile Test

Machine Type	UTM		Serial No	51301002
Test Method	ASTM A370 Ed:2024a			
Procedure No.	ITI/SOP01/Rev.10		Required	Actual
Dimension, mm	Ø 12.63	Area, mm ²	-	125.28
Yield Load, kN	43.97	Yield Strength, MPa	350min	351
Ultimate Tensile Load, kN	66.37	Ultimate Tensile Strength, MPa	450min	530
Initial Gage Length, mm	50.00	Final Gage Length, mm	-	61.85
% Elongation, 20min	24	% Reduction of Area	50min	62
Final Diameter, mm	7.78	-	-	-

Charpy 2mm V-Notch Impact Test -N/A

Test Method			Procedure No	
Machine Type			Serial No	
Dimension, mm			Location	
Orientation			Temperature	
Sample details	Specimen A	Specimen B	Specimen C	Average
Energy Absorbed Joules	-	-	-	-

MATERIAL TEST REPORT (Page 2of 2)(PHY-100520)

CHEMICAL ANALYSIS

Test Method	ASTM E415 Ed:2021				Procedure No	ITI/SOP08/Rev.02	
Machine Type	OES				Serial No	22011846	
Element	C	Si	Mn	P	S	Cu	Al
Wt%	0.170	0.091	0.713	0.016	0.005	0.012	0.031
Requirement %	0.15-0.20	0.10max	0.60-0.90	0.030max	0.035max	-	0.02min



Remarks:The Sample tested above meets the requirement of ASTM A108 Gr.C1010-C1020

Tested By	Authorized By	Witnessed/Client
Name: Jenifer	Name:	
Designation:	Designation:	
Signature: 	Signature: 	
Date: 03/02/2026	Date: 03/02/2026	Date: 03/02/2026

F/ITI-LR/12-Issue 02 Rev.01

End of Report

Issue Date: 03/08/2020

This report pertaining to the provided sample tested & shall not be reproduced without prior written permission from ITI Dubai.
 This report is invalid without ITI Official Stamp & Signature.



TECHNICAL DATASHEETS

BUTYL SEALANT TAPE

Technical Data Sheet

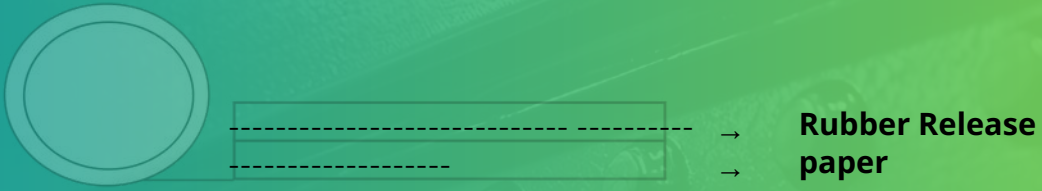
Item	MISBUTYL239519	Product Name	Sealed butyl tape
CONSTRUCTION			
Performance	Unit	standard of tolerance	REMARK
Thickness	mm	2.3	GB/T 7125-2014
density	g/cm ³	1.7±0.05	GB/T 533-2008
Penetration Index (1/10mm)	1/10mm	60±8	GB/T 269—1991
Elongation	%	450	ASTM D412-16
Clarity Humiditycl	g/m ² 24h	0.278	GB/T 12952-91
Peeling Force	N/CM	7	JC/T 942-2022
Tensile Strength	kpa	70	JC/T 942-2022
Dynamic Shear	N/mm (250mm/min)	≥12	GB/T 7124-2008
Water Solubility	%	0	Insoluble in water
Heat Resistance	160±2°C, 168h	NO FLOWING AND NO CRACKLING	JC/T 942-
Low temperature flexibility	-40°C, 72h	No-crackle ON SURFACE	2022 JC/T
Shelf Life	24 months in ambient conditions. 942-2022		
Test temperature :23°C Test humidity: 60%RH			
The above test data are the measured values under specific conditions, which are reference only and are not used as the basis for quality assurance. Please ensure product suitability for your use case.			

TRADE LICENSE AND DOCUMENTS

Certificate of Registration



This is to certify that the Quality Management System of

MIS TOOLS BUILDING METAL PRODUCTS TRADING L.L.C

Unit 139 A & B Dubai Maritime City, Dubai, United Arab Emirates, P.O. Box-52421

is in accordance with the requirements of the following standard

ISO 9001:2015

(Quality Management System)

SCOPE

Trading of Building Metal Products, Pipes & Fittings, Steel and Basic Steel Products, Bolts, Nuts, Screws, Nails, Non-Ferrous Metal, Building Hardware & Tools

(IAF Code: 29)

Certificate Number : 040225019731

Initial Registration Date : 20-Nov-2023

Current Certificate Date : 04-Feb-2025

2nd Surveillance Date : 20-Oct-2025

Certificate Expiry Date : 19-Nov-2026

To verify certificate, visit at :

www.arscert.com

www.uafaccreditation.org

www.iafcertsearch.org

Issued by ARS Assessment Private Limited

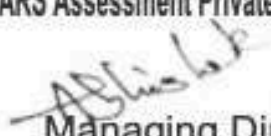
Managing Director



CB-M5-3923



ENGINEERING YOUR CONNECTIONS



UAF Address : 400, North Center Dr, STE 202, Norfolk, VA 23502, United States of America

This certificate remains the property of ARS and must be returned to ARS on Cancellation or Suspension of the certificate. Validity of the certificate is subject to successful completion of surveillance audits. Further clarification regarding the scope of this certificate and the applicability of standard may be obtained by consulting the Organisation on info@arscert.com



Our Presence

PHONE

Tel : +971 4 576 2560,
Mob : +971 58 563 5360/
+971 504574726
+971587991868

MAIL

sales@mis-eqpt.com
globalsales@mis-eqpt.com
uaesales@mis-eqpt.com

WEBSITE

www.mis-eqpt.com

ADDRESS

Unit 139A & B Dubai Maritime City,
P.O. Box 52421, Dubai - U.A.E



GROUP OF COMPANIES

Marine & Industrial Solutions LLC: Unit 139A & B Dubai Maritime City, P.O. Box 52421, Dubai - U.A.E

Liverpool, Oil & Gas Fields Equip. Manufacturing LLC, Sharjah UAE